



Slide units for pneumatic cylinder suitable for:

<p>ISO 6431 - 6432 cylinders M series Ø 16 ÷ 25 K/KD series Ø 32 ÷ 100</p>	<p>Slide units for rodless cylinders S1 series Ø 25 ÷ 50</p>	<p>Short-stroke cylinders W series Ø 25 ÷ 100</p>	<p>Compact cylinders STRONG RS series Ø 32 ÷ 63</p>	<p>2-stage telescopic cylinders RT2 series Ø 32 ÷ 63</p>
---	---	--	--	---

CONSTRUCTION CHARACTERISTICS

Enlarged chromium-plated hollow guides provide robustness and reliability

An economical solution thanks to the components used which ensure long life (7000 – 10000 km)

Special metallic self-lubricating bearings, minimizing noise and abrasion

Customized slide units available upon request

**High resistance to peak loads.
Scraper bearings standard supplied for J10-.../J31-... series**

All models available with safety distance 25 mm for accident prevention according to EC rules EN 349

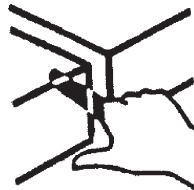

TECHNICAL CHARACTERISTICS

Working pressure:

2 ÷ 10 bar	3 ÷ 10 bar	2 ÷ 10 bar	2 ÷ 10 bar	2 ÷ 10 bar
------------	------------	------------	------------	------------

Ambient temperature:

- 20°C ÷ 80°C

SIZES

16 ÷ 100	40 ÷ 80	25 ÷ 100	32 ÷ 63	32 ÷ 63
----------	---------	----------	---------	---------

STANDARD STROKES (mm)

25 ÷ 1000	up to 800 mm max	5 ÷ 75	15 ÷ 800	120 ÷ 1200
-----------	------------------	--------	----------	------------

For min. and max. strokes refer to respective codification key.

In case there are protruding loads generating torque, the load and maximum torque values have to be reduced to 75%.

Mod. J10

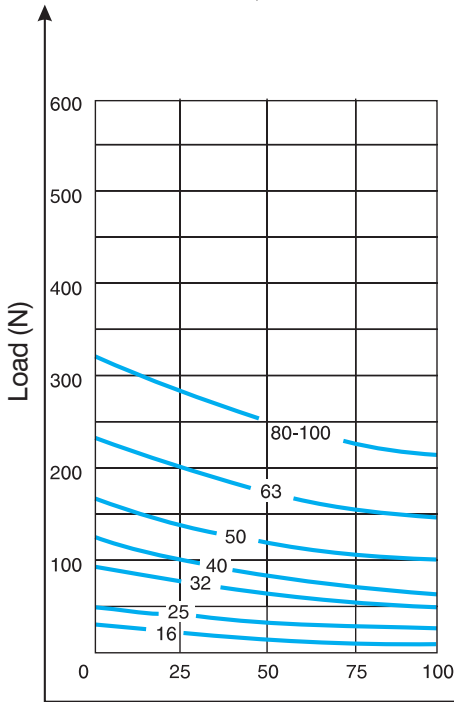
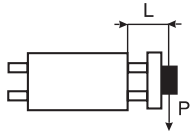

Mod. J11

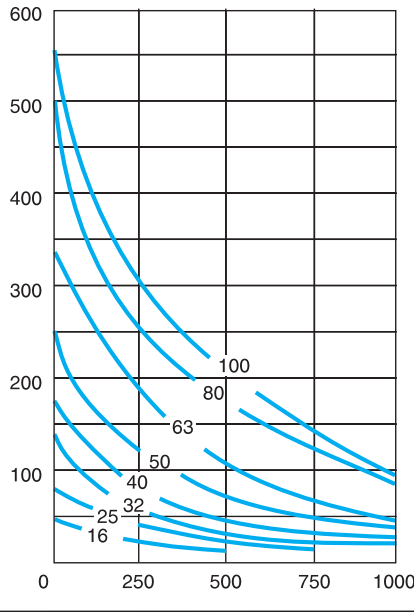
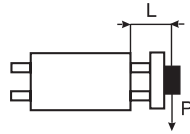

Mod. J12/J16/J17/J67

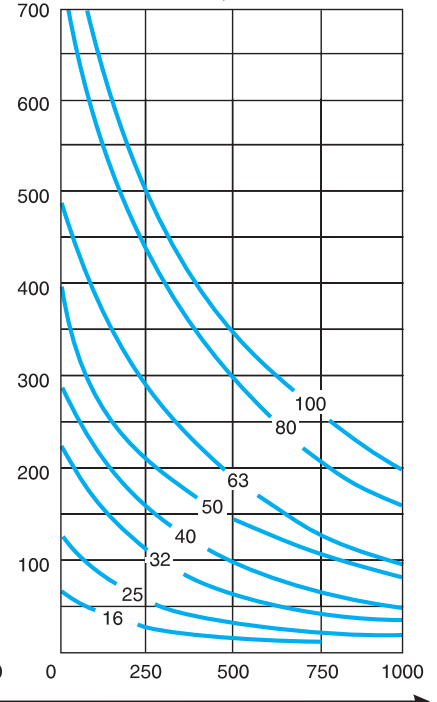
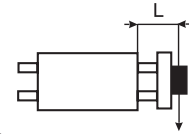

Mod. J14/J64

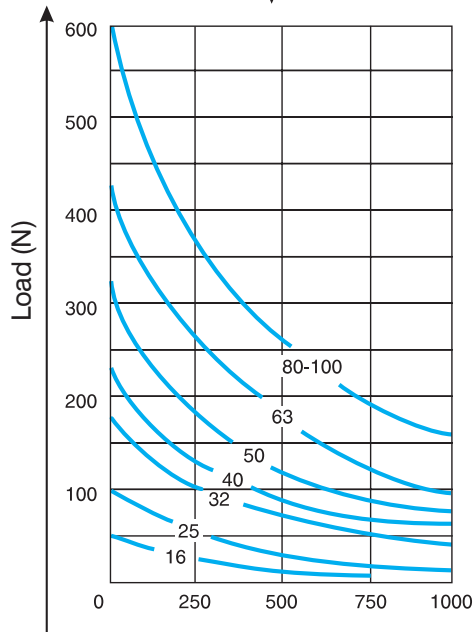
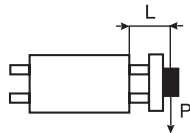

Mod. J16/J18/J19/J67

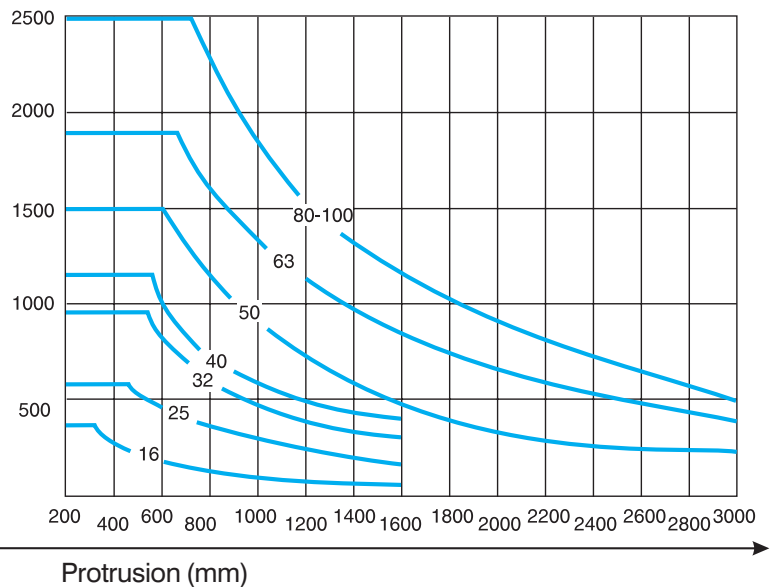
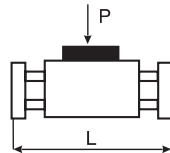

P = centre of application of the load

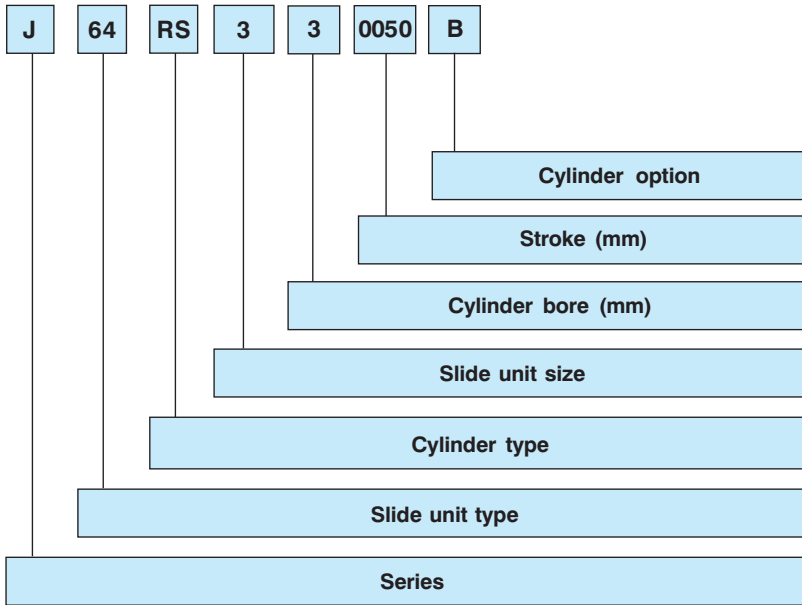

The slide units are supplied with safety distance (+ 25 mm) for accident prevention according to the European EN 349 specifications.



SERIES

J46RS = Slide units for STRONG Compact Cylinders Ø 32 ÷ 63 mm

SLIDE UNIT TYPE

64 = Fully protected.
65 = Fully protected with through opening.
66 = Fully protected with through opening, two plates
67 = Fully protected, two plates
 All types with scraper bearings.

CYLINDER TYPE

RS = Cylinder Strong with long piston (RS22J... upon request) the barrel of the supplied cylinder is turned by 180° compared with supply ports.*

SLIDE UNIT SIZE

3 = 32
4 = 40
5 = 50
6 = 63

CYLINDER BORE SIZE

3 = 32
4 = 40
5 = 50
6 = 63

STANDARD STROKES SLIDE UNITS

0015 ÷ 0800 mm

CYLINDER OPTIONS

A = Cylinder with long piston.
B = Cylinder with long piston and locking unit.

* to fit magnetic sensor

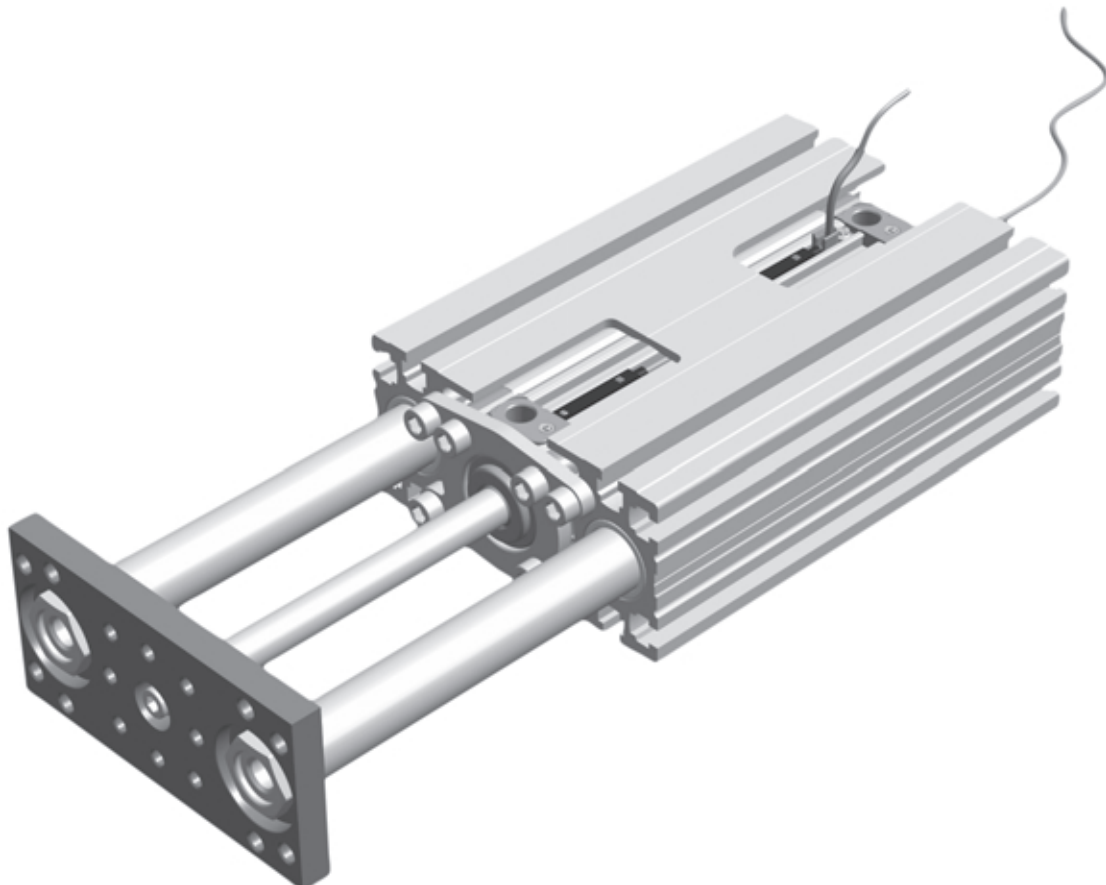



J64...., 2 bearings

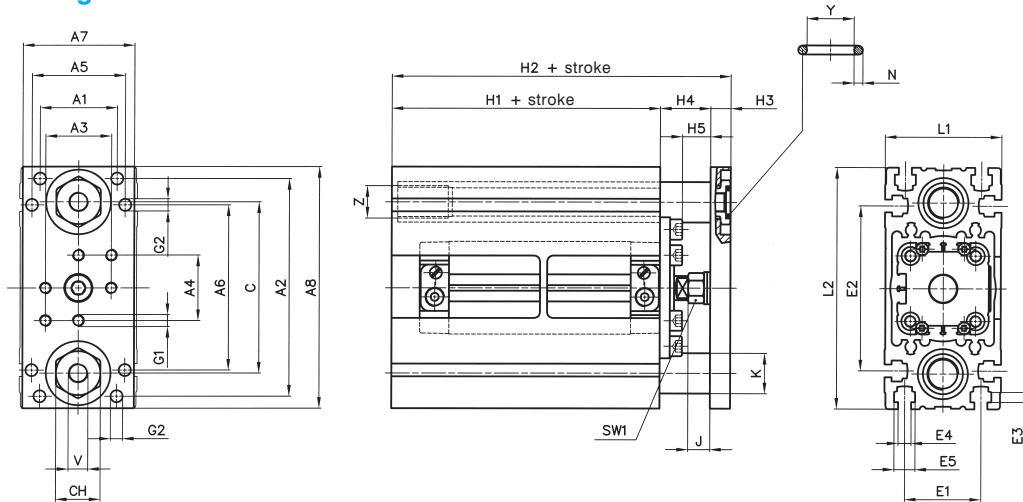

J65... upon request for strokes exceeding 50 mm slide units with through opening for placing the magnetic sensor in intermediate positions

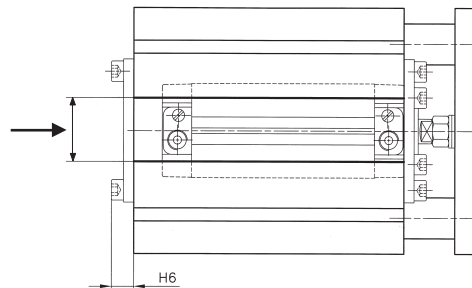

This version implies the increase of "H2" by the value "H6" indicated in the table.

Cyl. Ø	H6
32	11
40	12
50	14
63	14

Size of slide unit	Cyl. Ø	A1	A2	A3	A4	A5	A6	A7	A8	C	CH	E1	E2	E3	E4	E5	G1
32	32	38	108	32,5	32,5	46	82	55	120	85	22	38	82	5	6,4	10,4	M6
40	40	42	118	38	38	54	90	65	130	95	22	42	90	5	6,4	10,4	M6
50	50	48,1	140	46,5	46,5	69	110	80	155	115	27	48	110	6,5	8,4	13,4	M8
63	63	56	157,5	56,5	56,5	79,5	120	95	175	130	30	56	120	7,5	10,5	17,5	M8

Size of slide unit	Cyl. Ø	G2(*)	H1 + stroke (**)	H2+ stroke (**)	H3	H4	H5	J	K	L1	L2	N	SW1	V	Y	Z
32	32	Ø6 H8	78 + stroke (**)	113 + stroke (**)	10	25	14	11	20	58	120	2,62	13	1/8"	10,78	M16x1,5
40	40	Ø8 H8	82 + stroke (**)	117 + stroke (**)	10	25	13	11	22	66	130	2,62	16	1/8"	10,78	M18x1,5
50	50	Ø8 H8	91 + stroke (**)	128 + stroke (**)	12	25	11	7	25	84	155	2,62	18	1/8"	10,78	M20x1,5
63	63	Ø8 H8	98 + stroke (**)	135 + stroke (**)	12	25	11	7	28	98	176	2,62	18	1/8"	10,78	M22x1,5

Size of slide unit	Cyl. Ø	Mass "0" stroke (gr.)			Mass increase (gr.) per mm stroke		
		Slide unit	Cylinder	Locking units	Locking units	Shafts	Cylinder
32	32	1024	303	-	6	2,5	2,65
40	40	1325	483	-	7	2,8	4
50	50	2159	739	-	11	3,7	5,6
63	63	3025	1127	-	13,6	4,7	6,55

N.B.: on the 4 sides the plates for size 63 have chamfers as indicated in the following table:

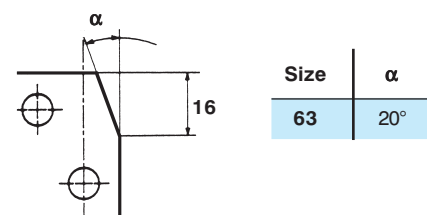

* For use with locating pin tolerance m6.

** Minimum stroke MAGNETIC CYLINDER for sizes 32 and 40 = 20 mm. / for sizes 50 and 63 = 15 mm.

NOTE: for all sizes up to 50 mm stroke the opening of the extrusion in accordance with the supply ports is of the through type.

J64...B, 2 bearings with locking unit

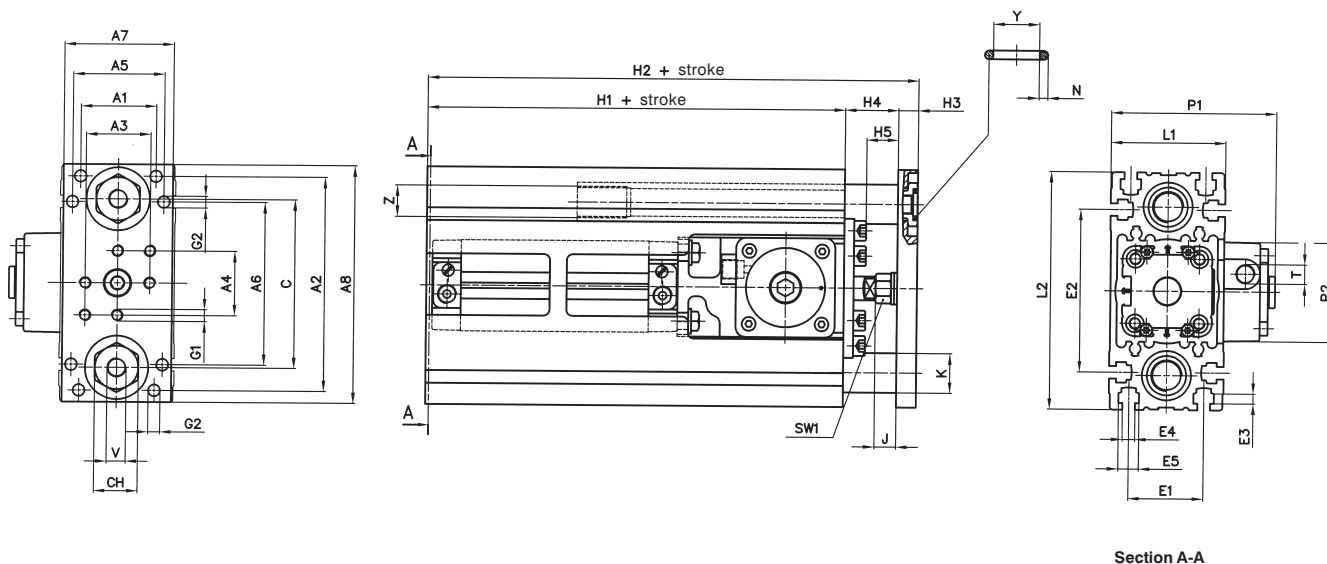

Slide unit size	Cyl. Ø	H1 + stroke (**)	H2+ stroke (**)	H4	H5	P1	P2
32	32	151 + stroke (**)	188 + stroke (**)	27	16	83,5	50
40	40	158 + stroke (**)	194 + stroke (**)	26	14	91,5	58
50	50	173 + stroke (**)	209 + stroke (**)	24	10	106,5	70
63	63	187 + stroke (**)	223 + stroke (**)	24	10	129	85

* For dimensions not indicated refer to page 51.

** Minimum stroke MAGNETIC CYLINDER for sizes 32 and 40 = 20 mm. / for sizes 50 and 63 = 15 mm.

Size	Cyl. Ø	Mass "0" stroke (gr.)			Mass increase (gr.) per mm stroke		
		Slide unit	Cylinder	Locking unit	Slide unit	Shafts	Cylinder
32	32	2241	303	779	6	2,5	2,65
40	40	2876	483	992	7	2,8	4
50	50	4590	739	1528,5	11	3,7	5,6
63	63	6606	1127	2370	13,6	4,7	6,55

For fixing elements refer to page 58.



J67...., 2 bearings

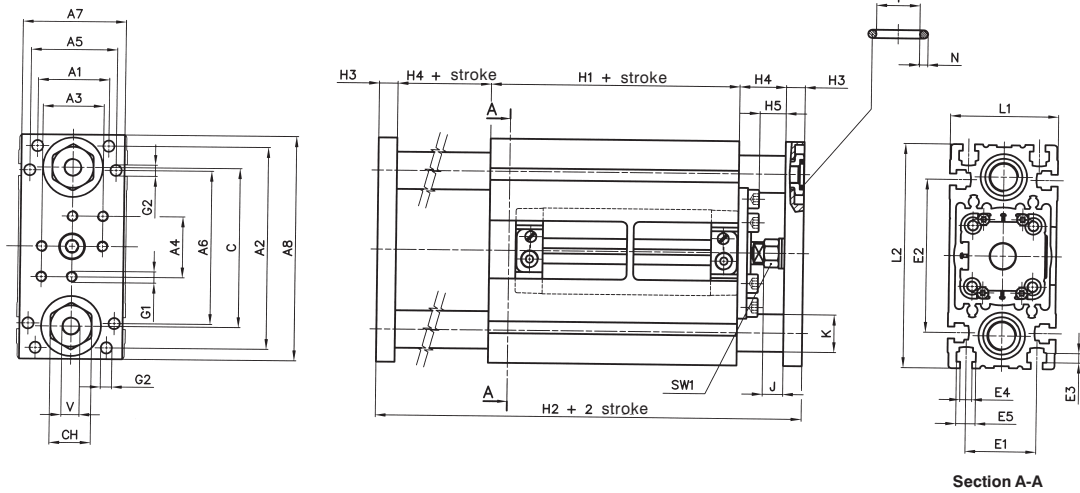

J66...B upon request for strokes exceeding 50 mm slide units with through opening for placing the magnetic sensor in intermediate positions

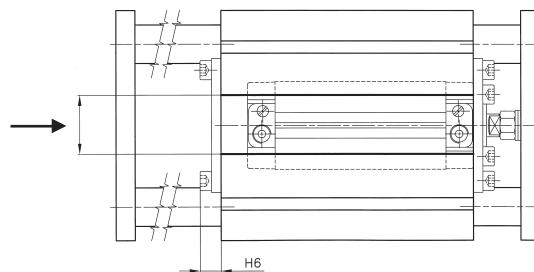

This version implies the increase of "H2" by the value "H6" indicated in the table.

Cyl. Ø	H6
32	11
40	12
50	14
63	14

Slide unit size	Cyl. Ø	A1	A2	A3	A4	A5	A6	A7	A8	C	CH	E1	E2	E3	E4	E5	G1
32	32	38	108	32,5	32,5	46	82	55	120	85	22	38	82	5	6,4	10,4	M6
40	40	42	118	38	38	54	90	65	130	95	22	42	90	5	6,4	10,4	M6
50	50	48,1	140	46,5	46,5	69	110	80	155	115	27	48	110	6,5	8,4	13,4	M8
63	63	56	157,5	56,5	56,5	79,5	120	95	175	130	30	56	120	7,5	10,5	17,5	M8

Slide unit size	Cyl. Ø	G2(*)	H1 + stroke (**)	H2+ 2 stroke (**)	H3	H4	H5	J	K	L1	L2	N	SW1	V	Y
32	32	Ø6 H8	78 + stroke (**)	148 + 2 stroke (**)	10	25	14	11	20	58	120	2,62	13	1/8"	10,78
40	40	Ø8 H8	82 + stroke (**)	152 + 2 stroke (**)	10	25	13	11	22	66	130	2,62	16	1/8"	10,78
50	50	Ø8 H8	91 + stroke (**)	165 + 2 stroke (**)	12	25	11	7	25	84	155	2,62	18	1/8"	10,78
63	63	Ø8 H8	98 + stroke (**)	172 + 2 stroke (**)	12	25	11	7	28	98	176	2,62	18	1/8"	10,78

Slide unit size	Cyl. Ø	Mass "0" stroke (gr.)			Mass increase (g) per mm stroke		
		Slide unit	Cylinder	Locking unit	Slide unit	Shafts	Cylinder
32	32	1092	330	-	6	2,5	2,65
40	40	1428	483	-	7	2,8	4
50	50	2264	739	-	11	3,7	5,6
63	63	3159	1127	-	13,6	4,7	6,55

N.B.: on the 4 sides the plates for sizes 63 have chamfers as indicated in the following table:

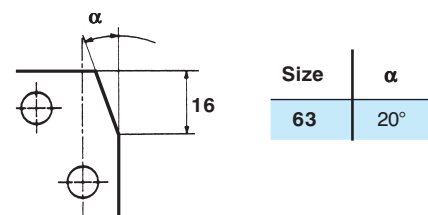

* For use with locating pin tolerance m6.

** Minimum stroke MAGNETIC CYLINDER for sizes 32 and 40 = 20 mm. / for sizes 50 and 63 = 15 mm.

NOTE: for all sizes up to 50 mm stroke the opening of the extrusion in accordance with the supply ports is of the through type.

J67...B, 2 bearings with locking unit

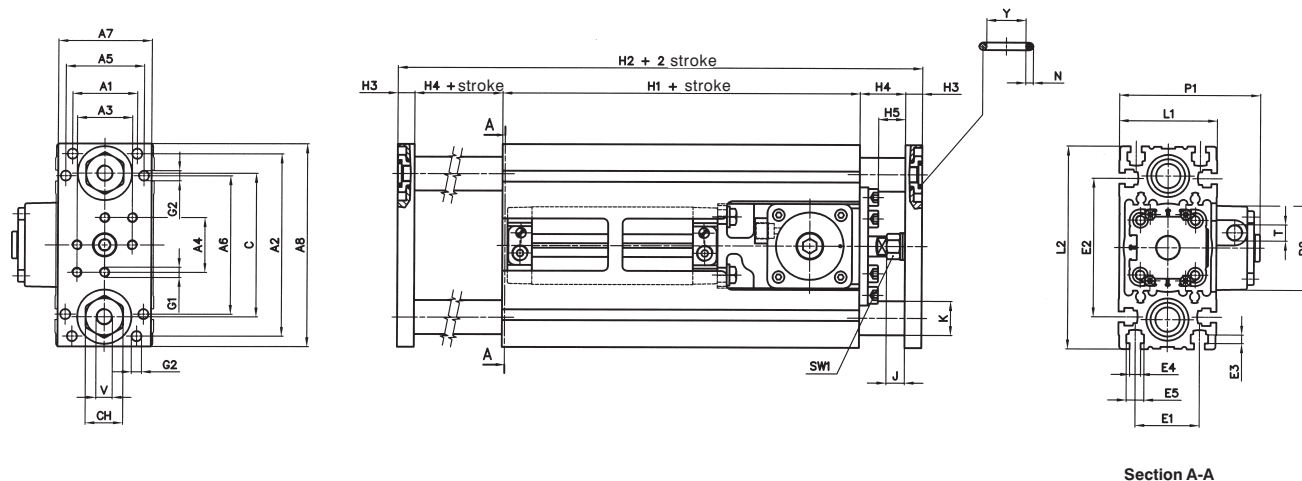

Slide unit size	Cyl. Ø	H1 + stroke (**)	H2+ stroke (**)	H4	H5	P1	P2
32	32	151 + stroke (**)	225 + stroke (**)	27	16	83,5	50
40	40	158 + stroke (**)	230 + stroke (**)	26	14	91,5	58
50	50	173 + stroke (**)	245 + stroke (**)	24	10	106,5	70
63	63	187 + stroke (**)	259 + stroke (**)	24	10	129	85

* For dimensions not indicated refer to page 53.

** Minimum stroke MAGNETIC CYLINDER for size 32 and 40 = 20 mm. / for size 50 and 63 = 15 mm.

Slide unit size	Cyl. Ø	Mass "0" stroke (gr.)			Mass increase (gr.) per mm stroke		
		Slide unit	Cylinder	Locking unit	Slide unit	Shafts	Cylinder
32	32	2492	303	779	6	2,5	2,65
40	40	3165	483	992	7	2,8	4
50	50	4998	739	1528,5	11	3,7	5,6
63	63	7153	1127	2370	13,6	4,7	6,55

For mounting accessories refer to section High-Tech page 58-II.

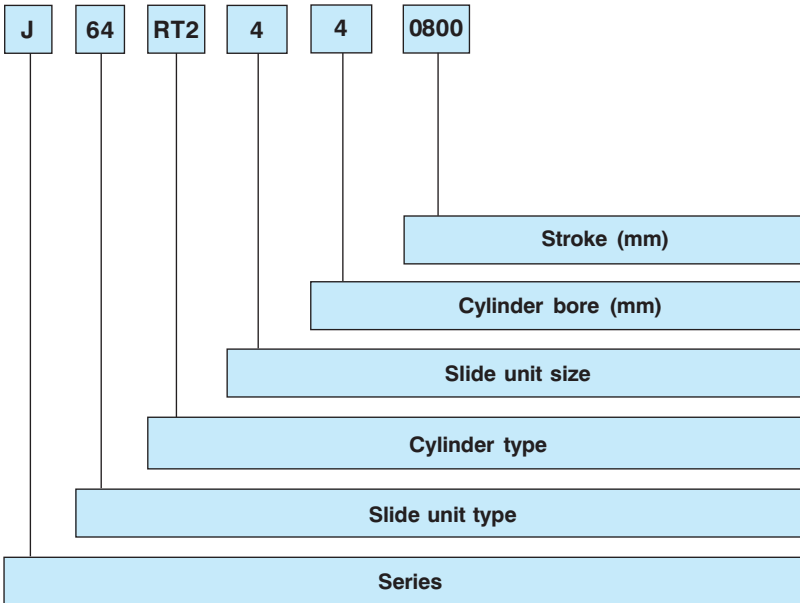

SERIES

J = Slide unit series

SLIDE UNIT TYPE

64 = slide unit for fully protected telescopic cylinder with scraper bearings.

CYLINDER TYPE

RT2 = 2-stage telescopic cylinder

SLIDE UNIT SIZE

- 3 = 32 only for cylinder Ø 32
- 4 = 40 only for cylinder Ø 40
- 5 = 50 only for cylinder Ø 50
- 6 = 63 only for cylinder Ø 63

CYLINDER BORE

- 3 = 32
- 4 = 40
- 5 = 50
- 6 = 63

SLIDE UNIT STROKE

Standard strokes in mm:
0120-0160-0180-0200-0300-0400-0500-0600-
0700-0800-0900-1000-1100-1200

Min-max stroke:

- Ø 32 0160 ÷ 0400 mm
- Ø 40 0160 ÷ 0600 mm
- Ø 50 0120 ÷ 0900 mm
- Ø 63 0120 ÷ 1200 mm

The slide units are supplied with safety distance (+ 25 mm) for accident prevention according to the European EN 349 specifications.

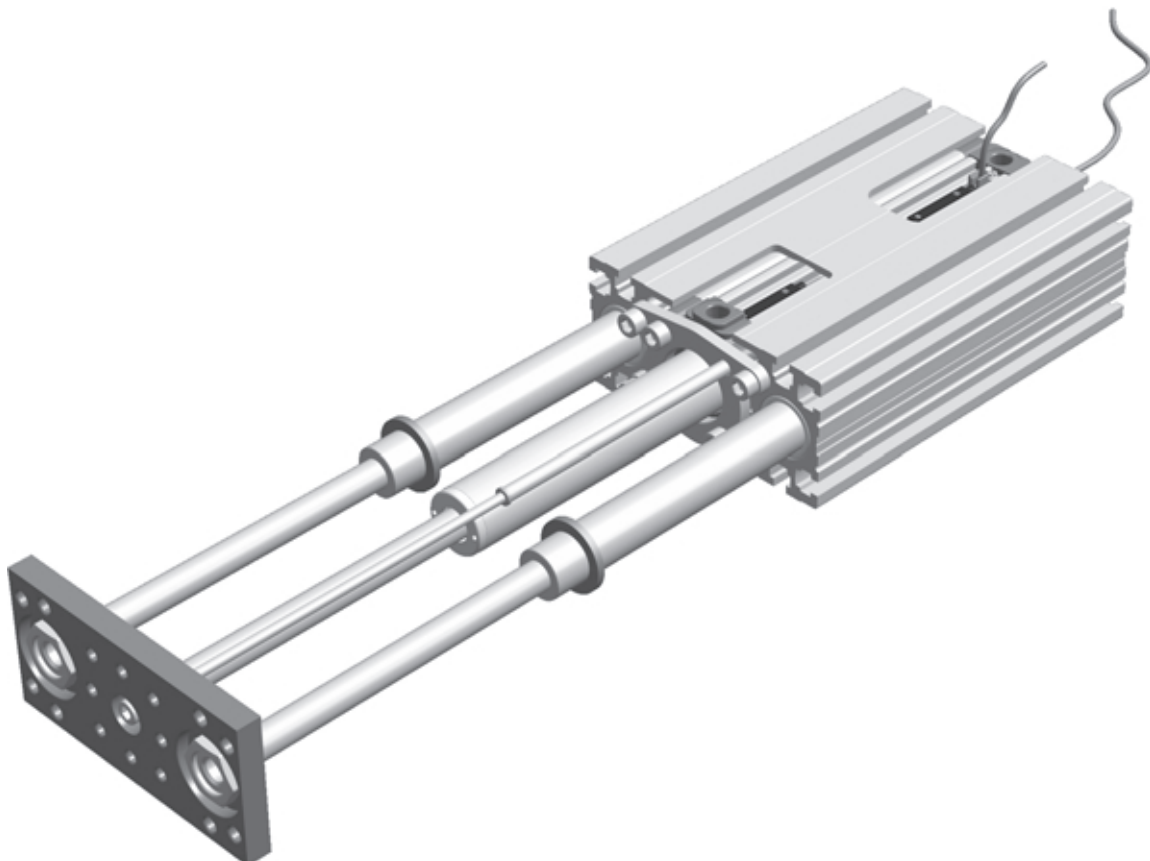
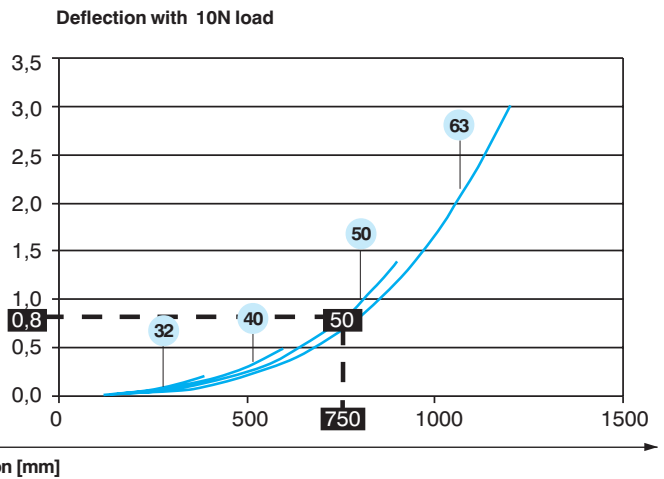
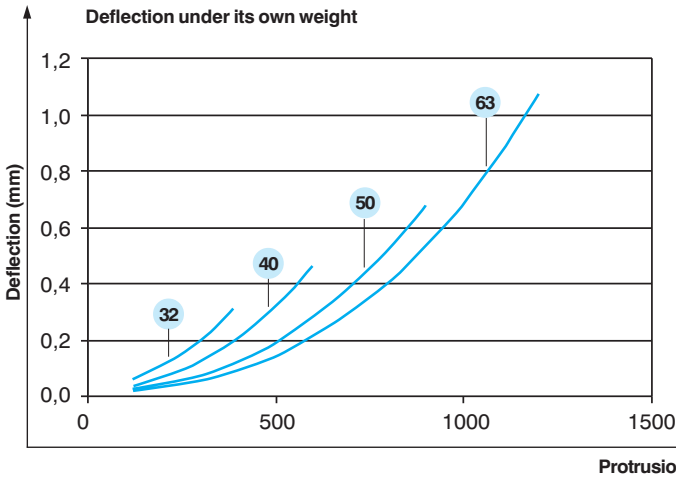
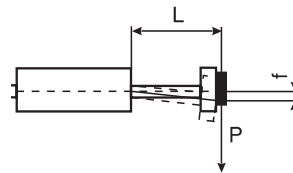
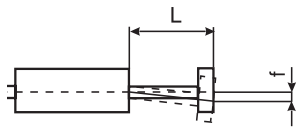



Diagram deflection per slide unit length



Example of application:

How to calculate deflection

The total deflection of the slide unit is calculated by summing deflection under its own weight to deflection caused by the load.

For loads other than 10N (as stated in the charts) deflection is calculated by multiplying the figure of chart (K) by the following formula:

$$f = K \cdot \frac{Q \text{ (applied load)}}{10 \text{ N}}$$

Ex: slide unit size **50**, length **750** mm and load Q of 25 N. On chart showing deflection with 10 N load, we get coefficient **0,8** (marked with negative print), then:

$$f = 0,8 \cdot \frac{25}{10} = 2 \text{ mm}$$

The figure obtained must be added to the corresponding figure of the slide unit deflection under the unit's own weight.

Max. moment of resistance MR

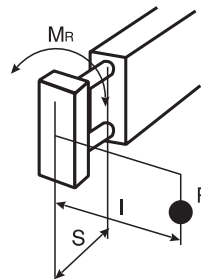

Size	MR
32	4,7
40	7,8
50	10,2
63	10,2

How to calculate torque

To calculate torque M1 the load P(N) must be multiplied by the arm I (mm).

$$M1 = P \cdot I$$

The figure obtained must be within MR values, as stated above: should it exceed these values, a slide unit of a bigger size must be used.

Diagram useful load per slide unit length

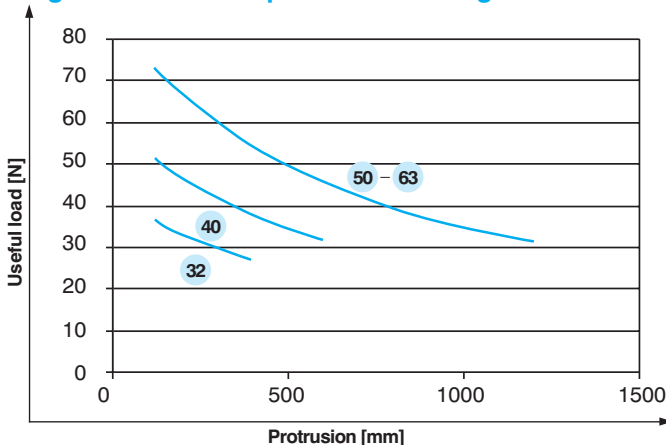

Maximum moments of resistance (Nm)

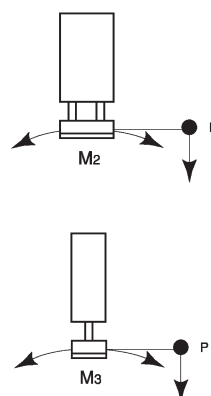

Size	M2=M3 Nm
32	7,4
40	12
50	17,8
63	17,8

Telescopic slide-unit, magnetic version J64RT2...

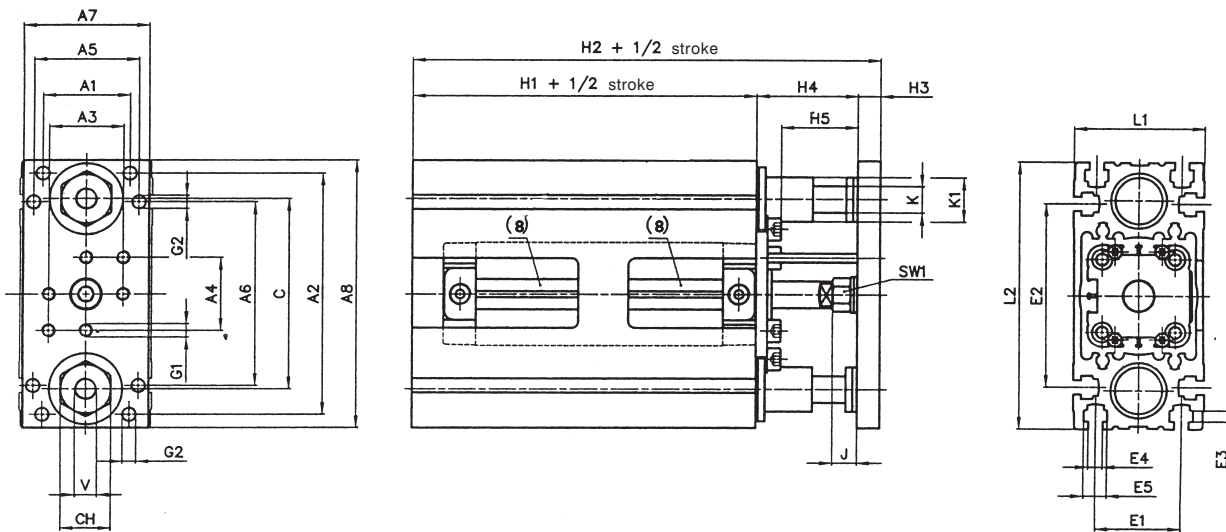

(♦) Attention: the magnetic sensors DF series must be placed near the telescopic stem of the magnet holder (as shown on the drawing).

Slide unit size	Cyl. Ø	A1	A2	A3	A4	A5	A6	A7	A8	C	CH	E1	E2	E3	E4	E5	G1
32	32	38	108	32,5	32,5	46	82	55	120	85	22	38	82	5	6,4	10,4	M6
40	40	42	118	38	38	54	90	65	130	95	22	42	90	5	6,4	10,4	M6
50	50	48,1	140	46,5	46,5	69	110	80	155	115	27	48	110	6,5	8,4	13,4	M8
63	63	56	157,5	56,5	56,5	79,5	120	95	175	130	30	56	120	7,5	10,5	17,5	M8

Slide unit size	Cyl. Ø	G2(*)	H1+1/2 stroke (**)	H2+1/2 stroke (**)	H3	H4	H5	J	K	K1	L1	L2	N	SW1	V	Y
32	32	Ø6 H8	72 + 1/2 stroke (**)	107 + 1/2 stroke (**)	10	25	16	12	12	20	58	120	2,62	13	G 1/8	10,78
40	40	Ø8 H8	78 + 1/2 stroke (**)	113 + 1/2 stroke (**)	10	25	15	13	14	22	66	130	2,62	16	G 1/8	10,78
50	50	Ø8 H8	92 + 1/2 stroke (**)	129 + 1/2 stroke (**)	12	25	14	10	16	25	84	155	2,62	18	G 1/8	10,78
63	63	Ø8 H8	95 + 1/2 stroke (**)	132 + 1/2 stroke (**)	12	25	14	10	16	28	98	176	2,62	18	G 1/8	10,78

Slide unit size	Cyl. Ø	Mass "0" stroke (gr.)			Mass increase (gr.) per mm stroke		
		Slide unit	Cylinder	Locking unit	Slide unit	Shafts	Cylinder
32	32	1092	330	-	6	2,5	2,65
40	40	1428	483	-	7	2,8	4
50	50	4590	739	-	11	3,7	5,6
63	63	3159	1127	-	13,6	4,7	6,55

N.B.: on the 4 sides the plates for sizes 63 have chamfers as indicated in the following table:

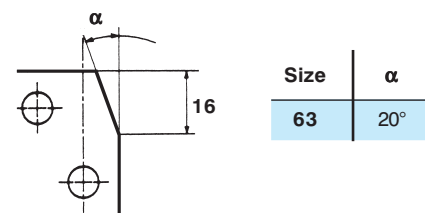

* For use with locating pin tolerance m6.

** Minimum stroke MAGNETIC CYLINDER for sizes 32 and 40 = 160 mm. (80+80) for sizes 50 and 63 = 120 mm. (60+60)



Aluminium foot brackets

SIZE	A	B	C	D	E	F	G	H	L	Part number
16	52	30	10	26	4	9	20	∅ 4,5	43	JF-13016
25	70	30	10	26	4	9	32	∅ 5,5	57	JF-13025
32	85	35	10	30	5	10	38	∅ 6,5	72	JF-13032
40	92	35	10	30	5	10	42	∅ 6,5	79	JF-13040
50	111	40	15	35	5	12,5	48	∅ 8,5	102	JF-13050
63	131	45	15	40	5	15	56	∅ 10,5	112	JF-13063
80	161	45	15	40	5	15	65	∅ 10,5	135	JF-13080
100	171	45	15	40	5	15	72	∅ 10,5	151	JF-13100

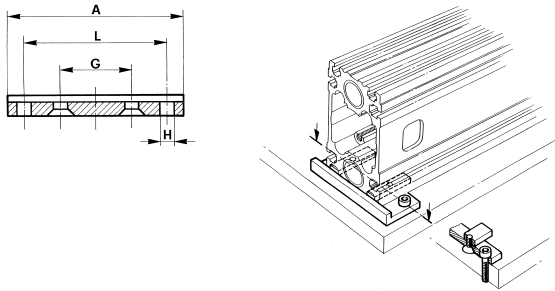

Package consists of 2 pcs. including mounting accessories.

Fixing plates in steel

SIZE	A	B	C	D	E	F	Part number
16	3	7	7,5	15	30	M4	JF-42016
25	4	8	10	15	35	M5	JF-42025
32 - 40	4	10	10	20	40	M6	JF-42040
50	6	13	10	30	50	M8	JF-42050
63	6	16	12,5	35	60	M10	JF-42063
80 - 100	8	16	15	40	70	M10	JF-42100

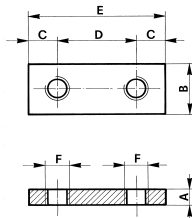

Package consists of 2 pcs. including mounting accessories.

Shaft support for slide units J10/J11/J12 Series

SIZE	Part number
16	JF-601016
25	JF-601025
32	JF-601032
40	JF-601040
50	JF-601050
63	JF-601063
80	JF-601080
100	JF-601100

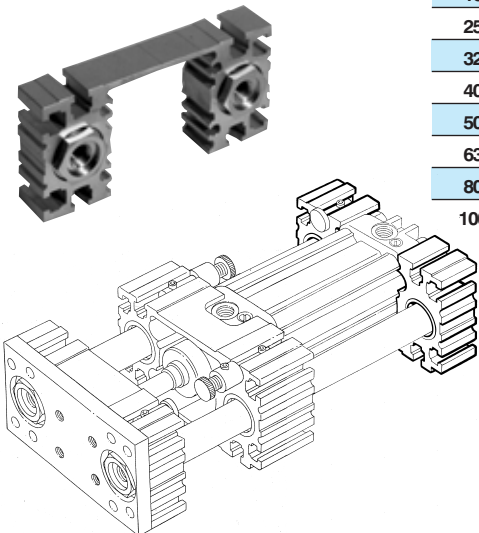

SIZE	A	B	C	D	E	F	G	H	Part number
16	50	30	10	26	3	9	31	∅ 4,5	JF-14016
25	55	30	10	26	3	9	34	∅ 5,5	JF-14025
32	60	35	10	30	4	10	38	∅ 6,5	JF-14032
40	65	35	10	30	4	10	40	∅ 6,5	JF-14040
50	70	40	15	35	4	12,5	45	∅ 8,5	JF-14050
63	85	45	15	40	4	15	56	∅ 10,5	JF-14063
80 - 100	90	45	15	40	4	15	58	∅ 10,5	JF-14100

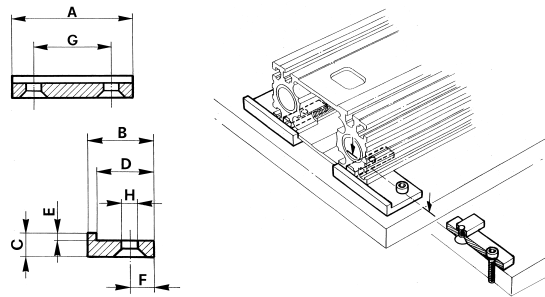

Package consists of 4 pcs. including mounting accessories.

SIZE	A	B	C	D	Part number
16	3	7	16	M4	JF-43016
25	4	8	16	M5	JF-43025
32 - 40	4	10	18	M6	JF-43040
50	6	13	18	M8	JF-43050
63	6	16	22	M10	JF-43063
80 - 100	8	16	25	M10	JF-43100

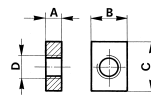

Package consists of 2 pcs. including mounting accessories.

Scraper bearings

SIZE	∅ A	Part number
16	12	JF-19016
25	16	JF-19025
32	20	JF-19032
40	22	JF-19040
50	25	JF-19050
63	28	JF-19063
80 - 100	32	JF-19100

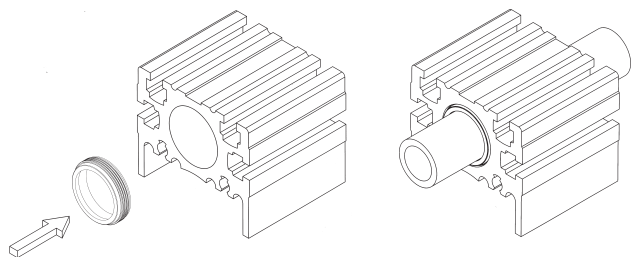
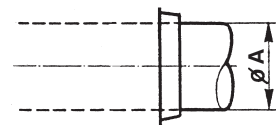

Package comprises 4 pcs.