



GENERAL FEATURES



- Supply: dry or lubricated filtered compressed air; pressure max. 8 BAR – 120 PSI (15 BAR – 225 PSI for Microcasting Stainless Steel pistons).
- The lubrication carried out by the manufacturer is guaranteed for min. 1,000,000 operations.
- Inside surface finish (Ra 0,4 – 0,6 um) to minimize friction and maximize the actuator's life.
- Piston bearing made by low friction coefficient material (LAT LUB) to avoid "metal to metal" contact, easily replaceable for maintenance.
- Double lower drilling, for fastening of the valve, and centering, according to ISO 5211 and DIN 3337 standards.
- Lower female shaft key, according to ISO 5211 and DIN 3337 standards, for assembly on valves with square key on line and 45° shaft.
- Solenoid connections according to NAMUR standards.
- Top drilling for fastening of the accessories, and upper shaft end according to NAMUR standards.
- Position indicator (fastening of upper switch-box is possible).
- Standard execution for temperatures from -20°C to +80°C (special execution for extremes temperatures on request).
- Adhesive labels on which the progressive number is automatically punched.
- Running test and 100% seal test carried out with electronic equipment and certification of each individual product.

Used Materials

BODY: Forged Stainless Steel type A182 - F316 – EN 10088/3 – 1.4401.

COVERS: Micro-casted Stainless Steel type A182 - F316 – EN 10088/3 – 1.4401.

PISTONS: Die-casted aluminium alloy ASTM B179, anodized (special pistons in Micro-casted Stainless Steel A182 - F316 – EN 10088/3 – 1.4401 on request).

SHAFT: Forged Stainless Steel type AISI 316 (A4).

PISTON BEARINGS: acetalic resin (LAT LUB 731320T) + 20% PTFE (PA66 ZYTEL on request).

SCREWS: Stainless Steel type AISI 316 (A4).

SPRINGS: Precompressed cartridge, painted with polyester powder.

SEALS: Nitrile rubber NBR (VITON o SILICONE on request).

GREASE: Molybdenum Bisulphide (MOLYKOTE on request).

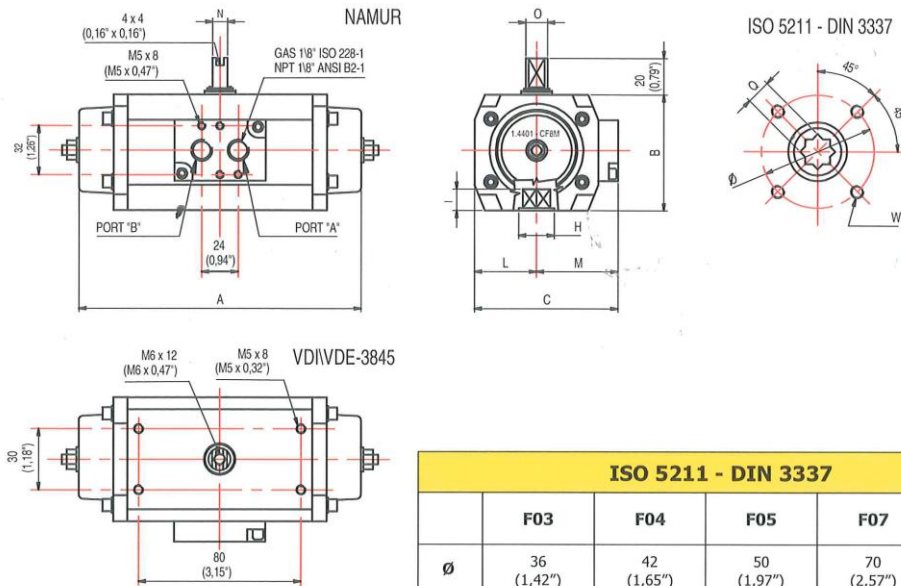

Dimensioni - Dimensions - Maße - Dimensions									
	ISO 5211 DIN 3337	Q x I	A	B	C	L	M	N	O
AP 042-A	F03\05 F04	11 x 13 (0,43" x 0,51")	140 (5,50")	57 (2,24")	71 (2,79")	30,5 (1,20")	40,5 (1,59")	8 (0,31")	12 (0,47")
			"Y" (120°) A=194 (7,94") F03\05 H=25 (0,98")		"X" (180°) A=230 (9,05") F04 H=30 (1,18")				
AP 050-A	F03\05 F04	11 x 13 (0,43" x 0,51")	138 (5,43")	67 (2,63")	93 (3,65")	41,5 (1,63")	51,5 (2,02")	8 (0,31")	12 (0,47")
			"Y" (120°) A=172 (6,77") F03\05 H=25 (0,98")		"X" (180°) A=211 (8,31") F04 H=30 (1,18")				
AP 063-A	F03\05 F05\07	14 x 16 (0,55" x 0,63")	152 (5,97")	83 (3,26")	93 (3,65")	41,5 (1,63")	51,5 (2,02")	8 (0,31")	12 (0,47")
			"Y" (120°) A=201 (7,91") F03\05 H=25 (0,98")		"X" (180°) A=220 (8,66") F05\07 H=30 (1,18")				
AP 075-A	F05\07	17 x 20 (0,67" x 0,79")	210 (8,27")	100 (3,93")	108 (4,24")	49 (1,93")	59 (2,32")	14 (0,55")	18 (0,71")
			"Y" (120°) A=249 (9,80") F05\07 H=40 (1,57")		"X" (180°) A=298 (11,73") F05\07 H=40 (1,57")				
AP 085-A	F05\07	17 x 20 (0,67" x 0,79")	230 (9,04")	110 (4,32")	118 (4,64")	54 (2,12")	64 (2,52")	14 (0,55")	18 (0,71")
			"Y" (120°) A=282 (11,01") F05\07 H=40 (1,57")		"X" (180°) A=338 (13,31") F05\07 H=40 (1,57")				
AP 100-A	F07\10	22 x 25 (0,87" x 0,98")	257 (10,81")	125 (4,91")	135 (5,30")	62,5 (2,46")	72,5 (2,85")	14 (0,55")	18 (0,71")
			"Y" (120°) A=332 (13,07") F07\10 H=55 (2,15")		"X" (180°) A=401 (15,79") F07\10 H=55 (2,15")				

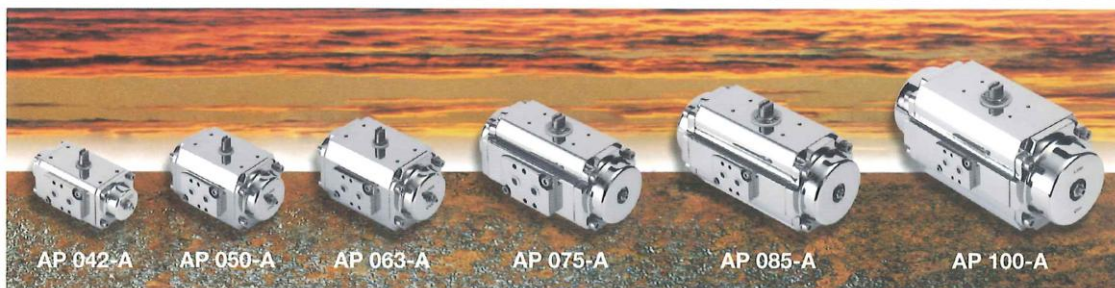



Torsioni attuatori a Doppio Effetto in Nm Torsion des Antriebs mit Doppeleffekt in Nm							Actuators Double Acting torque in Nm Torsion d'actionneur à Double Effet en Nm							PESO WEIGHT GEWICHT POIDS
TIPO TYPE TYP TYPE	Alimentazione aria in BAR Luftspeisung in BAR						Air supply in BAR Alimentation d'air en BAR							
	Pistoni in alluminio Aluminium Kolbens			Aluminium pistons Pistons en aluminium			Pistoni in Acciaio Inox Rostfrei Stahl Kolbens			Stainless Steel pistons Pistons en Acier Inoxydable				
	3	4	5	6	7	8	9	10	11	12	13	14	15	
042-A DA	6,5	8,7	10,9	13,0	15,2	17,3	19,5	21,7	23,9	26,0	28,2	30,4	32,6	Kg. 1,950
050-A DA	9,2	12,3	15,4	18,5	21,5	24,6	27,7	30,8	33,8	36,9	40,0	43,1	46,2	Kg. 2,770
063-A DA	16,5	22,0	27,5	33,0	38,5	44,0	49,5	55,0	60,5	66,0	71,5	77,0	82,5	Kg. 3,520
075-A DA	35,1	46,8	58,5	70,2	81,9	93,6	105,3	117,0	128,7	140,4	152,1	163,8	175,5	Kg. 6,800
085-A DA	53,4	71,2	89,0	106,9	124,7	142,4	160,3	178,1	195,9	213,7	231,5	249,3	267,1	Kg. 9,240
100-A DA	83,2	110,9	138,6	166,4	194,1	221,8	249,5	277,3	305,0	332,8	360,5	388,2	416,0	Kg. 12,760

Torsioni attuatori a Semplice Effetto in Nm Torsion des Antriebs mit Einfacheffekt in Nm							Actuators Single Acting torque in Nm Torsion d'actionneur à Simple Effet en Nm							PESO WEIGHT GEWICHT POIDS	
TIPO TYPE TYP TYPE	Alimentazione aria in BAR Luftspeisung in BAR						Air supply in BAR Alimentation d'air en BAR						SPRING STROKE		
	3		4		5		6		7		8		90° 0°		
	0°	90°	0°	90°	0°	90°	0°	90°	0°	90°	0°	90°	90°	0°	
042-A SR 3\3 042-A SR 4\4	-	-	-	-	7,1	4,1	9,3	6,3	11,5	8,5	13,7	10,7	6,8	3,8	Kg. 2,010 Kg. 2,030
050-A SR 3\3 050-A SR 4\4 050-A SR 5\5 050-A SR 6\6	5,7	3,5	8,9	6,6	12,0	9,6	15,1	12,7	18,1	15,7	21,2	18,8	5,7	3,5	Kg. 2,835 Kg. 2,860 Kg. 2,880 Kg. 2,900
063-A SR 3\3 063-A SR 4\4 063-A SR 5\5 063-A SR 6\6	9,4	6,3	14,9	11,7	20,4	17,2	25,9	22,7	31,4	28,2	36,9	33,7	10,2	7,2	Kg. 3,620 Kg. 3,655 Kg. 3,690 Kg. 3,720
075-A SR 3\3 075-A SR 4\4 075-A SR 5\5 075-A SR 6\6	22,5	12,6	34,2	24,4	46,0	36,1	57,7	47,8	69,4	59,5	81,1	71,2	22,5	12,6	Kg. 7,040 Kg. 7,110 Kg. 7,190 Kg. 7,270
085-A SR 3\3 085-A SR 4\4 085-A SR 5\5 085-A SR 6\6	34,5	18,9	52,4	36,7	70,2	54,5	88,0	72,3	105,8	90,1	123,6	107,9	34,5	18,9	Kg. 9,550 Kg. 9,660 Kg. 9,770 Kg. 9,880
100-A SR 3\3 100-A SR 4\4 100-A SR 5\5 100-A SR 6\6	53,2	30,0	80,9	57,7	108,7	85,4	136,4	113,1	164,1	140,8	191,8	168,5	53,2	30,0	Kg. 13,270 Kg. 13,440 Kg. 13,610 Kg. 13,780

ATTENZIONE ! Tipo "Y" (120°) e "X" (180°): solo funzionamento a Doppio Effetto, con pistoni in alluminio.
 ATTENTION PLEASE ! "Y" (120°) and "X" (180°) types: only Double Acting available, with aluminium pistons.
 ACHTUNG ! Typ "Y" (120°) und "X" (180°): nur Antrieben mit Doppeleffekt, mit aluminum Kolben verfügbar.
 ATTENTION ! Type "Y" (120°) et "X" (180°): seulement en version Double Effet, avec pistons en aluminium.



Sanitary
flow
equipment

PNEUMATIC ACTUATOR

STANDARD VERSION FEATURES

- **ASTM 6063 T6 extruded Aluminium Body**, inside surface finish Ra=0,4-0,6. 25 micron Hard Anodizing.
- **EN AB 46100 die-casted Aluminium alloy Pistons**, 15 micron Anodizing.
- **EN AB 46100 die-casted Aluminium alloy Covers**, painted with 60-80 micron polyester powder.
- **Carbon steel Shaft**, 20 micron nickel-plated. Optional in Stainless Steel AISI 316 (A4).
- **External adjusting gear**, in Stainless Steel AISI 316 (A4).
- Screws in Stainless Steel AISI 304 (A2).
- Seals in nitrile nubber NBR.
Optional HIGH Temperature = FPM\FKM.
Optional LOW Temperature = SILICONE.
- Bearings in low friction acetal resin LAT-LUB, easily replaceable for maintenance.
Optional HIGH/LOW Temperature = PA 66.
- Pre-compressed Spring Cartridges, easily replaceable for maintenance, 25-30 micron polyester painted.
- Standard grease: Molibdenum Bisulphide.
Optional: special grease for HIGH/LOW Temperature.
- Several special protections available for chemical, pharmaceutical, food and industrial environments.

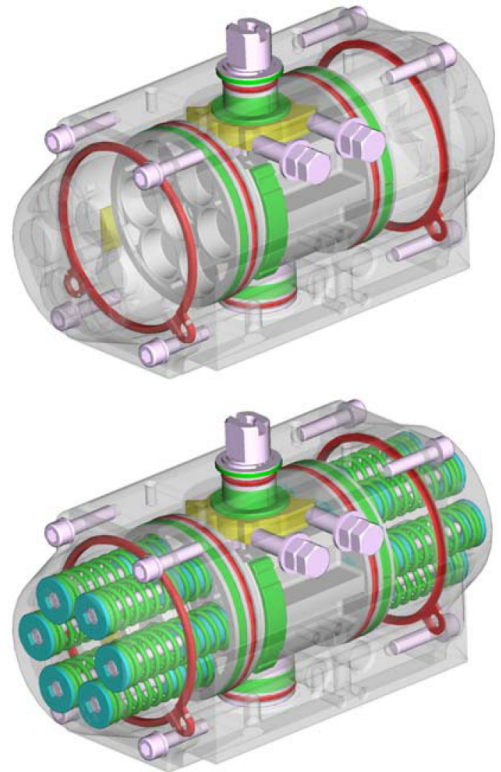

- Supply: dry or lubricated compressed air.
- Working pressure = 8 BAR - 120 PSI. Max. = 10 BAR – 145 PSI.
- Rotation adjustment $\pm 5^\circ$ in both opening and closing position. Assembly precision $\pm 1^\circ$, made by electronic devices.
- Double lower drilling for valve fastening and centering, according to **ISO 5211-DIN 3337 Standards**.
- Double square lower female shaft key (starlike), according to **ISO 5211-DIN 3337 Standards** for assembly on valves with square key on line (0°) and diagonal key (45°).
- Solenoid connections according to **NAMUR VDI\VDE-3845 Standards**.
- Top drilling for accessories fastening, and upper shaft end according to **NAMUR VDI\VDE-3845 Standards**.
- Position indicator on request, enabling switch-box assembly on top.
- Aluminium adhesive nameplates, with progressive serial number punched.
- Lubrication carried out by the manufacturer, guaranteed for min. 1.000.000 operations.
- Running test and 100% seal test carried out with electronic equipment and certification of each individual product.
- Standard execution for temperatures from -20°C to $+80^\circ\text{C}$ (optional, special execution for extreme temperatures).
- According to **ATEX-94-9-CEE Standard** for explosive environment;
STANDARD version actuator: II 2GD c Tmax = 95°C.
- According to **CEN\TC69\WG1\SG10** design and manufacture standard requirements.

Aerre Innox s.r.l.

26010 FIESCO via Gerola n.4 -CREMONA- Italy
Tel. +39. 0374. 370828 Fax +39. 0374. 370833
e-mail : info@aerreinox.it http : www.aerreinox.it



Sanitary
flow
equipment

CONSTRUCTION PARTS – SPECIFICATIONS

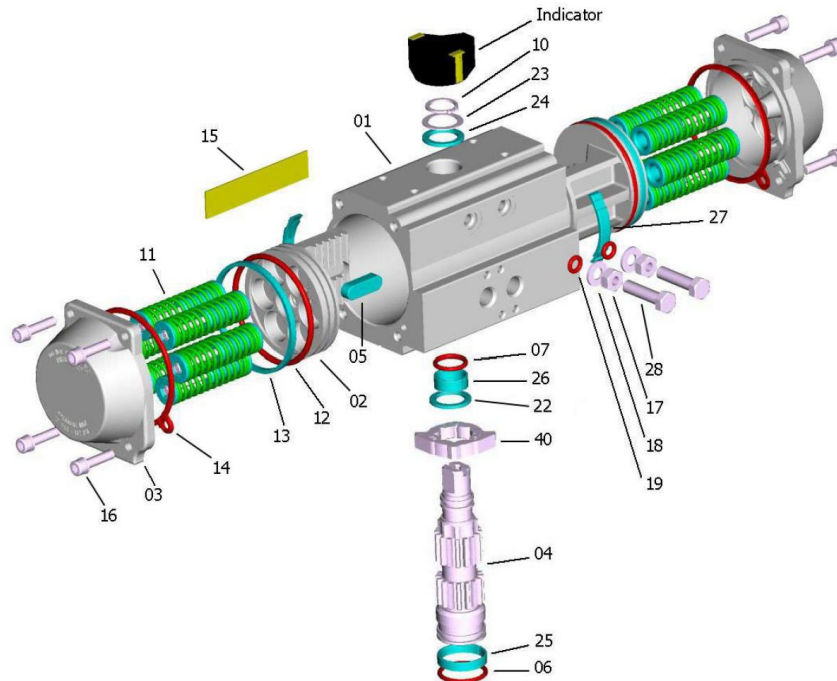

PART	QUANTITY	DESCRIPTION	MATERIAL	SPECIFICATION	PROTECTION
1	1	Body	Extruded aluminium alloy	ASTM 6063 T6	A - N - TF
2	2	Piston	Aluminium alloy	EN AB 46100	A
3	2	Cover	Aluminium alloy	EN AB 46100	N - V - TF
4	1	Shaft	Carbon steel optional Stainless Steel	ASTM A105 AISI 316 (A4)	N
5 *	2	Antiejection key	Acetalic resin – PA66 – PA66		
6 *	1	Lower shaft O-Ring	NBR - FPM\FKM - Silicone		
7 *	1	Upper shaft O-Ring	NBR - FPM\FKM - Silicone		
10 *	1	Seeger ring	Carbon steel		N
11	0-12	Spring cartridge	Carbon steel, PA 66, S.S.	C-98	V
12 *	2	Piston O-Ring	NBR - FPM\FKM - Silicone		
13 *	2	Piston head bearing	Acetalic resin – PA66 – PA66		
14 *	2	Cover gasket	NBR - FPM\FKM - Silicone		
15	1	Nameplate	Aluminium		
16	4+4	Cover fastening screw	Stainless Steel	AISI 304 (A2)	
17	2	Nut	Stainless Steel	AISI 304 (A2)	
18	2	Washer	Stainless Steel	AISI 304 (A2)	
19 *	2	O-Ring	NBR - FPM\FKM - Silicone		
22 *	1	Gear antifriction washer	Acetalic resin – PA66 – PA66		
23 *	1	Shaft thrust washer	Stainless Steel	AISI 304 (A2)	
24 *	1	Shaft antifriction washer	Acetalic resin – PA66 – PA66		
25 *	1	Lower shaft pilot ring	Acetalic resin – PA66 – PA66		
26 *	1	Upper shaft pilot ring	Acetalic resin – PA66 – PA66		
27 *	2-4	Piston bearing	Acetalic resin – PA66 – PA66		
28	2	Piston screw	Stainless Steel	AISI 304 (A2)	
40	1	External adjusting gear	Stainless Steel	AISI 316 (A4)	
* SPARE PARTS SET:		Standard	Special HIGH Temperatures	Special LOW Temperatures	
Protections					
		A = Anodizing	N = chemical Nickel-plating	V = Painting	TF = Anodizing+PTFE

Aerre Inox s.r.l.

26010 FIESCO via Gerola n.4 -CREMONA- Italy
Tel. +39. 0374. 370828 Fax +39. 0374. 370833
e-mail : info@aerreinox.it http : www.aerreinox.it



ROTATION ADJUSTMENT

The rotation adjustment is now easier.
Rotation adjustment operations are made through apposite external screws, with immediate verification of the result, and without actuator disassembly.
The gear\shaft tooling is high precision made, and this guarantees no mechanical clearances inside, with maximum precision of rotation adjustment and maximum lifetime!

Below figures show the rotation adjustment operations, as intended per STANDARD "A" and "B" assembly variation actuators, that have clockwise "CW" closing rotation.

P.N. "C" and "D" assembly variation actuators have counter-clockwise "CCW" enclosure rotation, so adjustments shall be made by the opposite screws.

The actuator's closing rotation is punched and shown on the nameplate: as "CW" (clockwise), or "CCW" (counter-clockwise). See ASSEMBLY VARIATION sheet.

CLOSING rotation adjustment

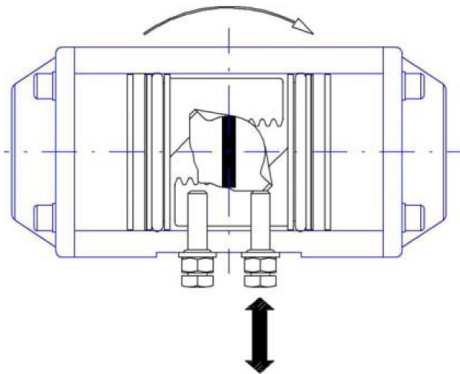

OPENING rotation adjustment

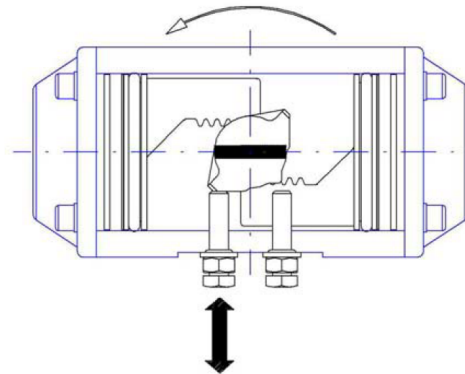



ACTUATOR WORKING TEMPERATURES

A few important points has to be considered about how to order and install ALPHAIR pneumatic actuators in high or low temperature environments. The two most common examples concern applications in hot or cold surroundings or those involving direct contact with sources of heat.

In case of hot or cold environment, it is important to know that devices will slowly tend to get as hot or cold as their surroundings. In some cases a protective screen may be placed between automated valve and its surroundings. But if this is not enough, the exact temperature must be measured and actuators have to be ordered with components for high or low temperature.

In case of direct contact with sources of hot or cold (for example actuators applied to valves where hot or cold fluid passes), a direct assembly of the actuator onto the valve is not recommended: where possible, a bracket and an adapter should be placed between them, thus reducing the hot contact surface just to the pinion's head. In spite of using bracket and adapter, it may be cheaper to order actuators with components for high or low temperature.

Following tables describe different ALPHAIR executions.

VERY LOW TEMPERATURE		-60° + 80°C (-76 +175°F)
Plastic antifriction components Sealing o-rings and gaskets Grease Nameplate adhesive		LEXAN EXL1330 Silicone Kluber ISOFLEX TOPAS L32 3M 9473 Hard acrylic
LOW TEMPERATURE		-40° + 80°C (-40 +175°F)
Plastic antifriction components Sealing o-rings and gaskets Grease Nameplate adhesive		Polyamide PA66 (Zytel) Silicone Kluber ISOFLEX TOPAS L32 3M 9473 Hard acrylic
STANDARD TEMPERATURE		-20° + 80°C (-4 +175°F)
Plastic antifriction components Sealing o-rings and gaskets Grease		AcetalicResin LAT-LUB + 15% PTFE NBR Rubber Esso MOLY EP2 - Agip SM2 SE
HIGH TEMPERATURE		-20° + 150°C (-4 +300°F)
Plastic antifriction components Sealing o-rings and gaskets Grease Nameplate adhesive		Polyamide PA66 (Zytel) FPM/FKM Rubber Kluber PARALIQ GB363 - MOLYKOTE 1102 3M 9473 Hard acrylic

Attention must be paid when taking environment temperature: no responsibility is undertaken for actuator's applications that are not duly carried out.

Working temperature of complete actuators is punched on every identification nameplate.

Aerre Inox s.r.l.

26010 FIESCO via Gerola n.4 -CREMONA- Italy
Tel. +39. 0374. 370828 Fax +39. 0374. 370833
e-mail : info@aerreinox.it http : www.aerreinox.it

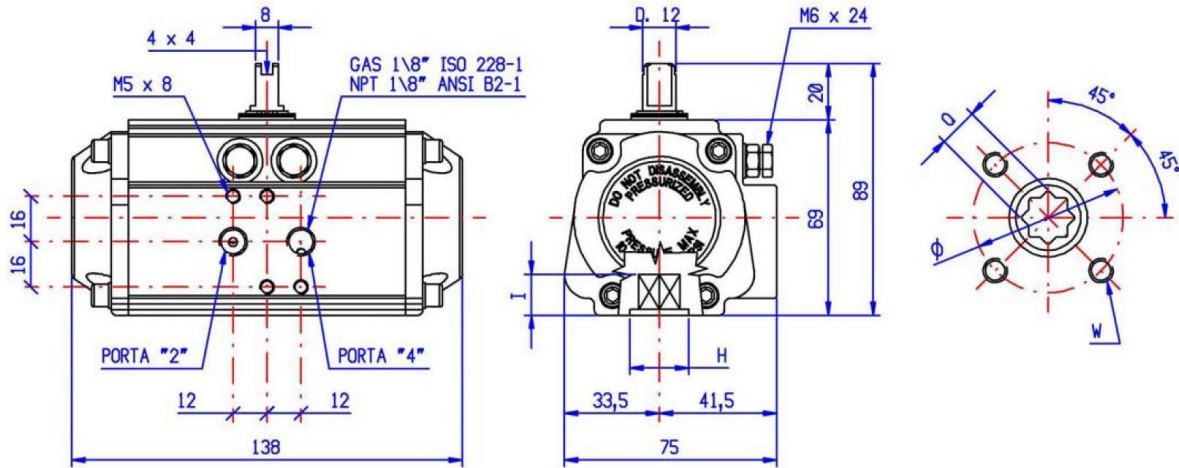

AVAILABLE FORCE INTAKES F03 - F03\05 - F04 - F05				
ISO 5211	F03	F04		F05
Ø	36	42		50
W	M 5x8	M 5x8		M 6x9
Q	9 11	9 11	9 11	9 11
I	10 13	10 13	10 13	10 13
H	25	30		35

DOUBLE ACTING TORQUE RATINGS IN NEWTONxMETRE (Nm)									WEIGHT kg
RE 051 DA	AIR SUPPLY IN BAR								
	3	4	5	6	7	8	9	10	
		10,9	14,5	18,1	21,7	25,3	28,9	32,6	36,2

SPRING RETURN TORQUE RATINGS IN NEWTONxMETRE (Nm)													WEIGHT kg		
RE 051 SR	AIR SUPPLY IN BAR											SPRINGS			
	3		4		5		6		7		8			END	START
	0°	90°	0°	90°	0°	90°	0°	90°	0°	90°	0°	90°	90°	0°	
SR 3\3	6,6	4,1	10,3	7,7	13,9	11,3	17,5	15,0	21,1	18,6	24,7	22,2	6,7	4,2	1,075
SR 4\4	5,2	1,9	8,9	5,5	12,5	9,1	16,1	12,7	19,7	16,3	23,3	20,0	9,0	5,6	1,095
SR 5\5			7,4	3,2	11,1	6,9	14,7	10,5	18,3	14,1	21,9	17,7	11,2	7,0	1,114
SR 6\6					9,7	4,6	13,3	8,2	16,9	11,8	20,5	15,5	13,5	8,4	1,135

ADDITIONAL DATA						
Chamber Diam.	MAX.PRESSURE	ROTATION	VOLUME	CLOSING TIME	OPENING TIME	STD. GREASE
50 mm	8 BAR	90° ± 5°	0,3 litres	0,5 seconds	0,5 seconds	MOLYBDENUM BISULP.

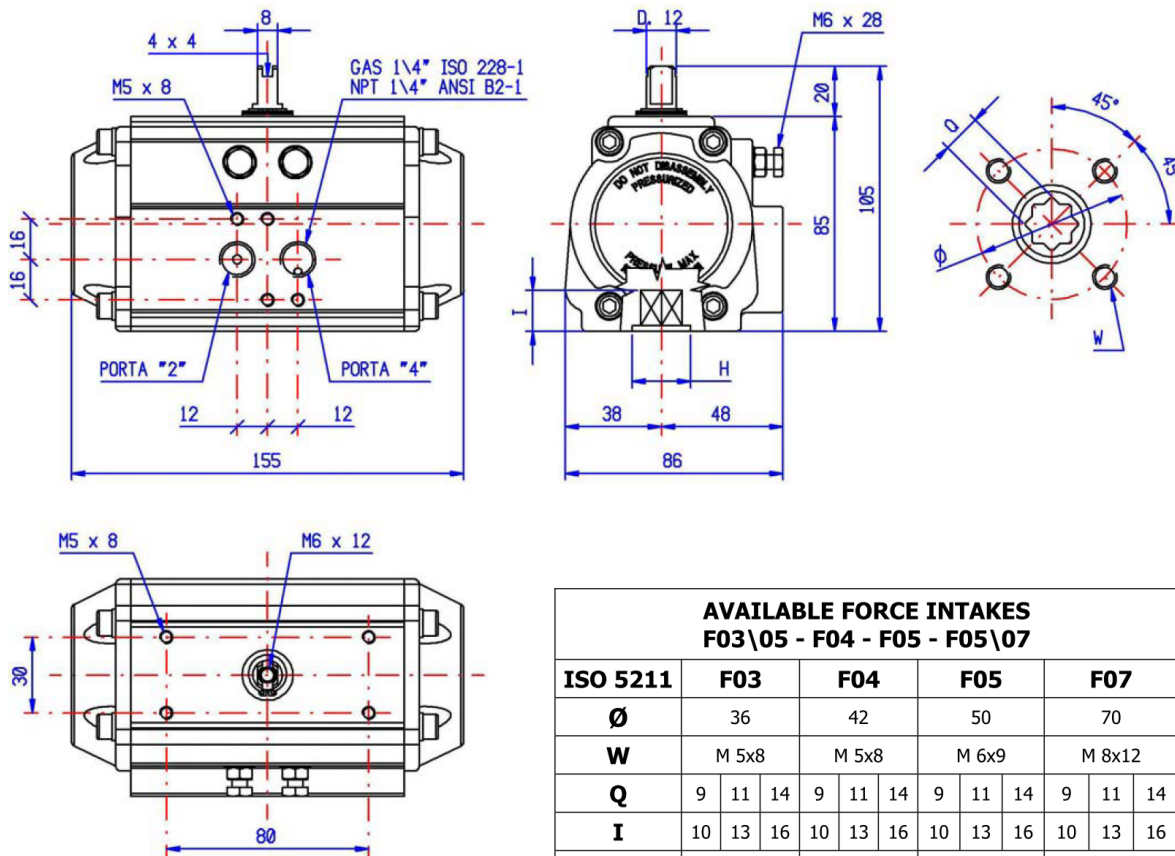

AVAILABLE FORCE INTAKES F03\05 - F04 - F05 - F05\07												
ISO 5211	F03			F04			F05			F07		
Ø	36			42			50			70		
W	M 5x8			M 5x8			M 6x9			M 8x12		
Q	9	11	14	9	11	14	9	11	14	9	11	14
I	10	13	16	10	13	16	10	13	16	10	13	16
H	25			30			35			35		

DOUBLE ACTING TORQUE RATINGS IN NEWTONxMETRE (Nm)										WEIGHT kg
RE 064 DA	AIR SUPPLY IN BAR									
	3	4	5	6	7	8	9	10		
		19,1	25,5	31,9	38,3	44,6	51,0	57,4	63,8	

SPRING RETURN TORQUE RATINGS IN NEWTONxMETRE (Nm)													WEIGHT kg		
RE 064 SR	AIR SUPPLY IN BAR														
	3		4		5		6		7		8			SPRINGS	
	0°	90°	0°	90°	0°	90°	0°	90°	0°	90°	0°	90°		90°	0°
	SR 3\3	11,7	9,3	18,1	13,7	24,5	20,1	30,9	26,4	37,2	32,8	43,6	39,2	11,8	7,4
SR 4\4	9,3	3,4	15,7	9,8	22,0	16,1	28,4	22,2	34,8	28,9	41,2	35,3	15,7	9,8	1,625
SR 5\5			13,2	5,8	19,6	12,2	26,0	18,6	32,3	24,9	38,7	31,3	19,7	12,3	1,660
SR 6\6					17,1	8,3	23,5	14,6	29,9	21,0	36,2	27,4	23,6	14,8	1,695

ADDITIONAL DATA						
Chamber Diam.	MAX.PRESSURE	ROTATION	VOLUME	CLOSING TIME	OPENING TIME	STD. GREASE
63 mm	8 BAR	90° ± 5°	0,5 litres	0,5 seconds	0,5 seconds	MOLYBDENUM BISULP.

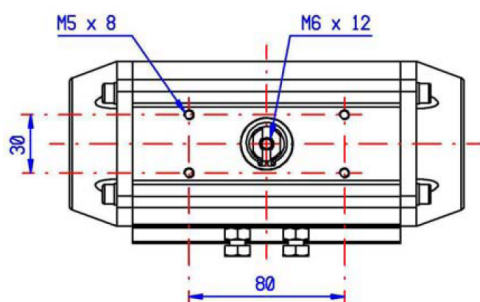
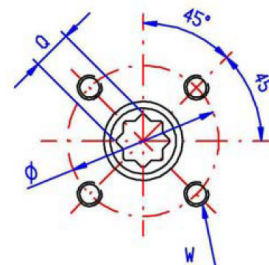
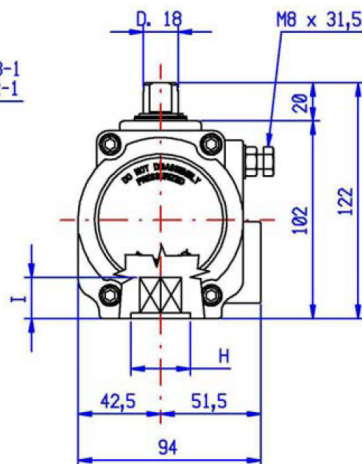
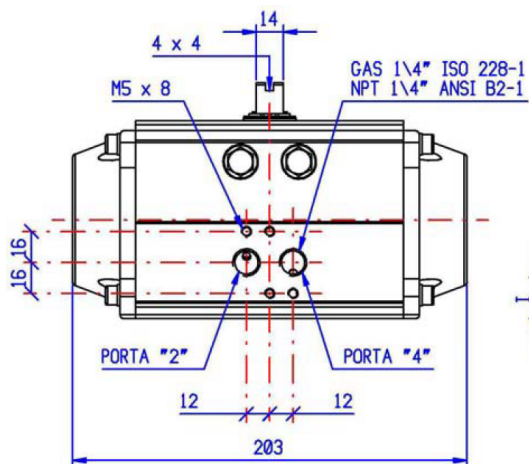

AVAILABLE FORCE INTAKES F04 - F05\07			
ISO 5211	F04	F05	F07
Ø	42	50	70
W	M 5x8	M 6x9	M 8x12
Q	11 14 17	11 14 17	11 14 17
I	13 16 20	13 16 20	13 16 20
H	30	35	35

DOUBLE ACTING TORQUE RATINGS IN NEWTONxMETRE (Nm)									WEIGHT kg
RE 076 DA	AIR SUPPLY IN BAR								
	3	4	5	6	7	8	9	10	
		37,9	50,6	63,2	75,9	88,5	101,1	113,8	126,4

SPRING RETURN TORQUE RATINGS IN NEWTONxMETRE (Nm)													WEIGHT kg		
RE 076 SR	AIR SUPPLY IN BAR											SPRINGS			
	3		4		5		6		7		8			END	START
	0°	90°	0°	90°	0°	90°	0°	90°	0°	90°	0°	90°	90°	0°	
SR 3\3	23,3	14,5	36,0	27,2	48,6	39,8	61,2	52,5	73,9	65,1	86,5	77,8	23,4	14,6	2,720
SR 4\4	18,4	6,7	31,1	16,4	43,7	32,0	56,4	44,7	69,0	57,3	81,7	70,0	31,2	19,5	2,790
SR 5\5			26,2	11,6	38,9	24,2	51,5	36,9	64,1	49,7	76,8	62,2	39,0	24,4	2,860
SR 6\6					34,0	16,4	46,6	26,1	59,3	41,3	81,9	54,4	46,8	29,2	2,930

ADDITIONAL DATA						
Chamber Diam.	MAX.PRESSURE	ROTATION	VOLUME	CLOSING TIME	OPENING TIME	STD. GREASE
75 mm	8 BAR	90° ± 5°	0,7 litres	0,7 seconds	0,7 seconds	MOLYBDENUM BISULP.

Aerre Inox s.r.l.

26010 FIESCO via Gerola n.4 -CREMONA- Italy
Tel. +39. 0374. 370828 Fax +39. 0374. 370833
e-mail : info@aerreinox.it http : www.aerreinox.it

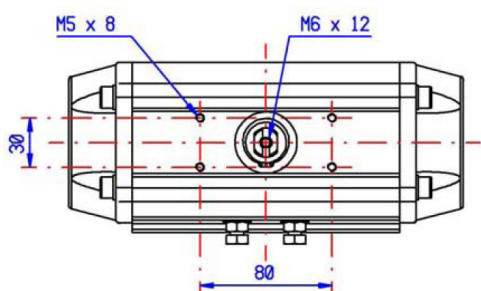
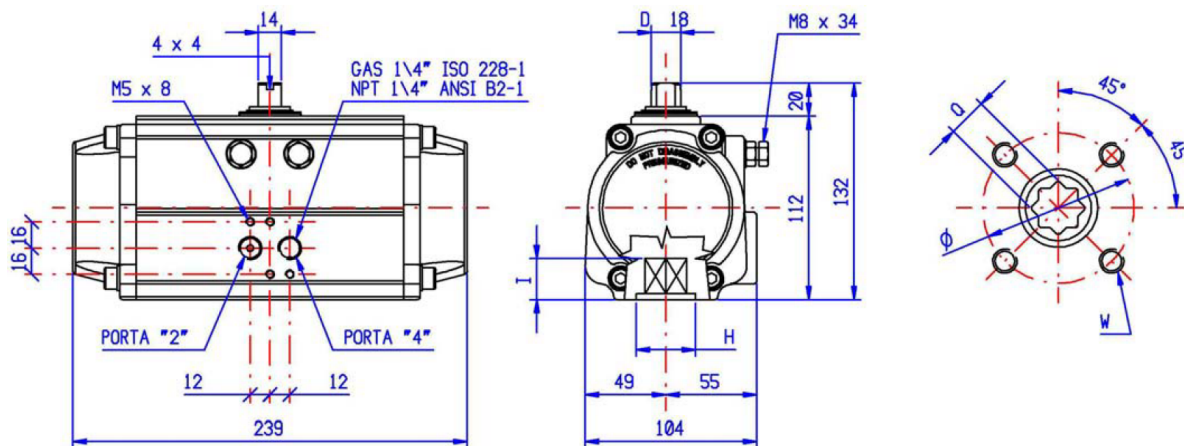

AVAILABLE FORCE INTAKES F05\07			
ISO 5211	F05		F07
Ø	50		70
W	M 6x9		M 8x12
Q	14	17	14 17
I	16	20	16 20
H	40		40

DOUBLE ACTING TORQUE RATINGS IN NEWTONxMETRE (Nm)									WEIGHT kg
RE 086 DA	AIR SUPPLY IN BAR								
	3	4	5	6	7	8	9	10	
		55,7	74,2	92,8	111,3	129,9	148,4	167,0	185,5

SPRING RETURN TORQUE RATINGS IN NEWTONxMETRE (Nm)													WEIGHT kg		
RE 086 SR	AIR SUPPLY IN BAR														
	3		4		5		6		7		8			SPRINGS	
	0°	90°	0°	90°	0°	90°	0°	90°	0°	90°	0°	90°	90°	0°	
SR 3\3	34,2	21,3	52,7	39,8	71,3	58,4	89,8	76,9	108,4	95,5	126,9	114,0	34,4	21,5	3,825
SR 4\4	27,0	9,8	45,5	28,3	64,1	46,9	82,7	65,4	101,2	84,0	119,8	102,6	45,9	28,7	3,935
SR 5\5			38,4	16,9	56,9	35,4	75,5	54,0	94,0	72,5	112,6	91,1	57,3	35,8	4,045
SR 6\6					49,8	24,0	68,3	42,5	86,9	61,1	105,4	79,6	68,8	43,0	4,155

ADDITIONAL DATA						
Chamber Diam.	MAX.PRESSURE	ROTATION	VOLUME	CLOSING TIME	OPENING TIME	STD. GREASE
85 mm	8 BAR	90° ± 5°	1,0 litres	0,8 seconds	0,8 seconds	MOLYBDENUM BISULP.

Aerre Inox s.r.l.

26010 FIESCO via Gerola n.4 -CREMONA- Italy
Tel. +39. 0374. 370828 Fax +39. 0374. 370833
e-mail : info@aerreinox.it http : www.aerreinox.it

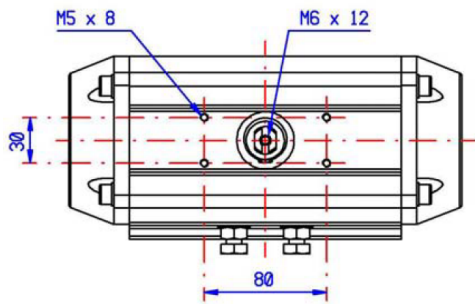
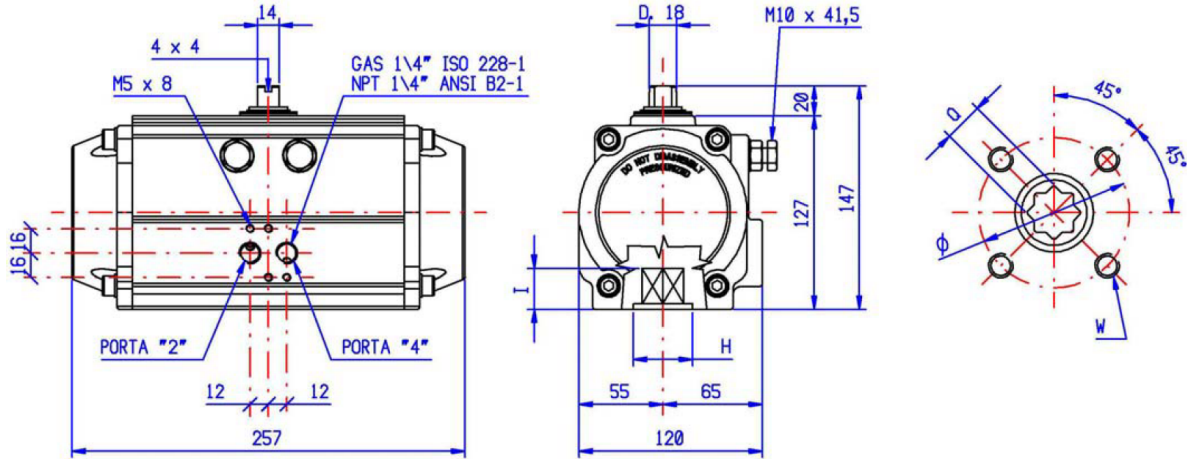

AVAILABLE FORCE INTAKES F5\7\10 – F07\10					
ISO 5211	F05		F07		F10
Ø	50		70		102
W	M 6x9		M 8x12		M 10x15
Q	17	22	17	22	17 22
I	20	25	20	25	20 25
H	40		55		55

DOUBLE ACTING TORQUE RATINGS IN NEWTONxMETRE (Nm)									WEIGHT kg
RE 101 DA	AIR SUPPLY IN BAR								
	3	4	5	6	7	8	9	10	
		86,6	115,5	144,4	173,3	202,2	231,0	259,9	288,8

SPRING RETURN TORQUE RATINGS IN NEWTONxMETRE (Nm)													WEIGHT kg		
RE 101 SR	AIR SUPPLY IN BAR											SPRINGS			
	3		4		5		6		7		8			END	START
	0°	90°	0°	90°	0°	90°	0°	90°	0°	90°	0°	90°		90°	0°
	SR 3\3	53,2	33,1	82,0	62,0	110,9	90,8	139,8	119,7	168,7	148,6	197,6	177,5	53,6	33,5
SR 4\4	42,0	15,2	70,9	44,1	99,8	73,0	128,6	101,9	157,5	130,7	186,4	159,6	71,4	44,6	5,325
SR 5\5			59,7	26,2	88,6	55,1	117,5	84,0	146,4	112,9	175,2	141,8	89,3	55,8	5,475
SR 6\6					77,4	37,3	106,3	66,1	135,2	95,0	164,1	123,9	107,1	67,0	5,625

ADDITIONAL DATA						
Chamber Diam.	MAX.PRESSURE	ROTATION	VOLUME	CLOSING TIME	OPENING TIME	STD. GREASE
100 mm	8 BAR	90° ± 5°	1,8 litres	0,9 seconds	0,9 seconds	MOLYBDENUM BISULP.

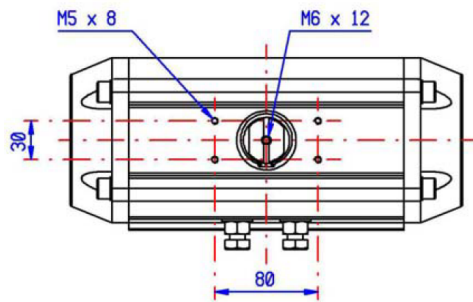
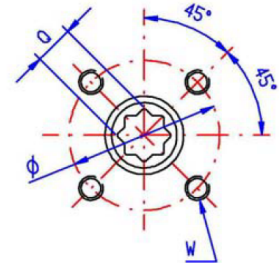
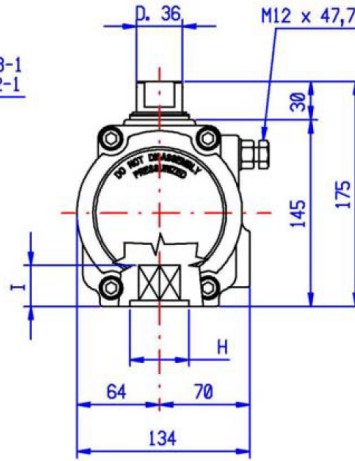
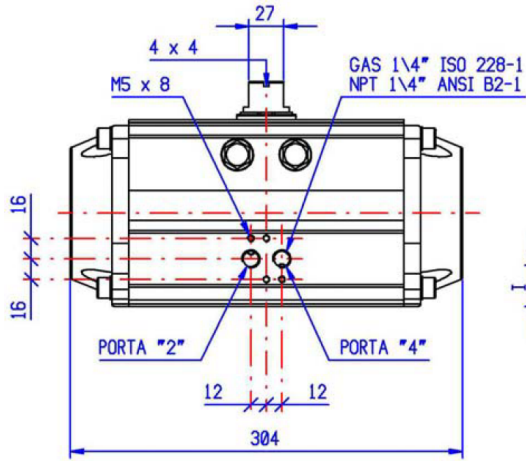

AVAILABLE FORCE INTAKES F07\10			
ISO 5211	F07		F10
Ø	70		102
W	M 8x12		M 10x15
Q	17	22	17 22
I	20	25	20 25
H	55		55

DOUBLE ACTING TORQUE RATINGS IN NEWTONxMETRE (Nm)									WEIGHT kg
RE 116 DA	AIR SUPPLY IN BAR								
	3	4	5	6	7	8	9	10	
	140,0	186,7	233,3	280,0	326,7	373,3	420,0	466,7	7,280

SPRING RETURN TORQUE RATINGS IN NEWTONxMETRE (Nm)														WEIGHT kg	
RE 116 SR	AIR SUPPLY IN BAR												SPRINGS		
	3		4		5		6		7		8		END		START
	0°	90°	0°	90°	0°	90°	0°	90°	0°	90°	0°	90°	90°		0°
SR 3\3	86,1	53,8	132,8	100,5	179,5	147,2	226,2	193,8	272,8	240,5	319,5	287,2	86,2	53,9	7,970
SR 4\4	68,2	25,1	114,9	71,8	161,5	118,5	208,2	165,1	254,9	211,8	301,5	258,5	114,9	71,8	8,200
SR 5\5			96,6	43,1	143,6	89,7	190,3	136,4	236,9	183,1	283,6	229,7	143,6	89,8	3,430
SR 6\6					125,6	61,0	172,3	107,7	219,0	154,3	265,6	201,0	172,3	107,7	8,660

ADDITIONAL DATA						
Chamber Diam.	MAX.PRESSURE	ROTATION	VOLUME	CLOSING TIME	OPENING TIME	STD. GREASE
115 mm	8 BAR	90° ± 5°	2,9 litres	1,0 seconds	1,0 seconds	MOLYBDENUM BISULP.

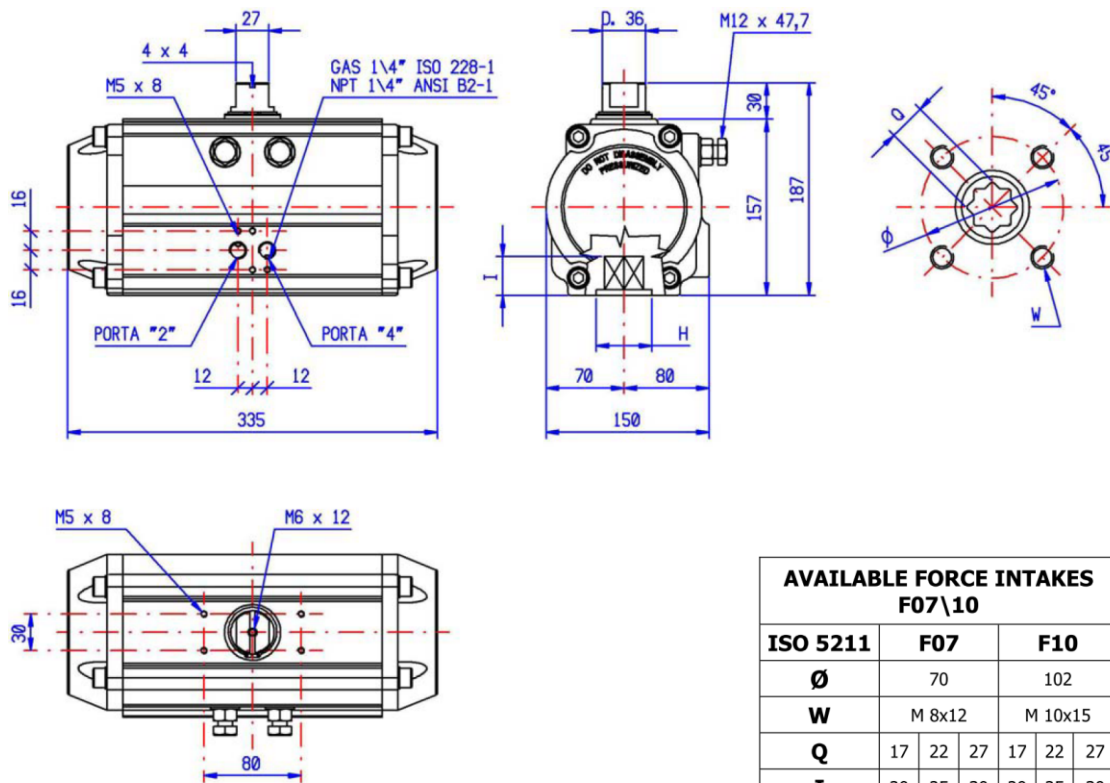

AVAILABLE FORCE INTAKES F07\10		
ISO 5211	F07	F10
Ø	70	102
W	M 8x12	M 10x15
Q	17 22 27	17 22 27
I	20 25 30	20 25 30
H	55	55

DOUBLE ACTING TORQUE RATINGS IN NEWTONxMETRE (Nm)									WEIGHT kg
RE 126 DA	AIR SUPPLY IN BAR								
	3	4	5	6	7	8	9	10	
		180,4	240,6	300,7	360,9	421,0	481,1	541,3	601,4

SPRING RETURN TORQUE RATINGS IN NEWTONxMETRE (Nm)												WEIGHT kg			
RE 126 SR	AIR SUPPLY IN BAR										SPRINGS				
	3		4		5		6		7		8		END	START	
	0°	90°	0°	90°	0°	90°	0°	90°	0°	90°	0°	90°	90°	0°	
SR 3\3	111,0	69,4	171,2	129,5	231,3	189,7	291,4	249,8	351,6	310,0	411,7	370,1	111,0	69,4	10,070
SR 4\4	87,9	32,4	148,0	92,5	208,2	152,7	268,3	212,8	328,4	273,0	388,6	333,1	148,0	62,5	10,470
SR 5\5			124,9	55,5	185,0	115,7	245,2	175,8	305,3	236,0	356,5	296,1	185,0	115,7	10,870
SR 6\6					161,9	78,7	222,0	138,8	282,2	198,9	342,3	259,1	222,0	138,8	11,270

ADDITIONAL DATA						
Chamber Diam.	MAX.PRESSURE	ROTATION	VOLUME	CLOSING TIME	OPENING TIME	STD. GREASE
125 mm	8 BAR	90° ± 5°	3,7 litres	1,2 seconds	1,2 seconds	MOLYBDENUM BISULP.

Get the information you need and more at : info@aerreinox.it

In the interests of development and improvement of the product, we reserve the right to change the specifications without prior notice.

Aerre Innox s.r.l.

26010 FIESCO via Gerola n.4 -CREMONA- Italy
Tel. +39. 0374. 370828 Fax +39. 0374. 370833
e-mail : info@aerreinox.it http : www.aerreinox.it