

# RT

## Ø 25 ÷ 63 mm - 2/3 stage Telescopic Pneumatic Cylinders

UNIVER Original design and technology  
 Industrialized components and advanced technology  
 Reduced dimensions: 60% less than standard cylinders  
 Non-rotating standard supplied  
 Magnetic version on stage 1 standard supplied (on stage 2 and 3 upon request)  
 Slide unit for two-stages version available (J64RT)

Available ATEX version upon request

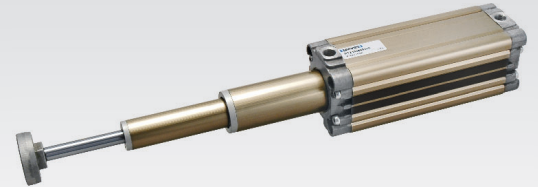

### TECHNICAL CHARACTERISTICS

Ambient temperature	-20 ÷ 80 °C
Fluid	filtered air, with or without lubrication
Working pressure	1,5 ÷ 10 bar
Bore	2 stages: Ø 25 - 32 - 40 - 50 - 63    3 stages: Ø 40 - 50 - 63

### CONSTRUCTIVE CHARACTERISTICS

End-caps	die-cast aluminium
Barrel	anodized aluminium
Piston	aluminium
Guide slide	acetalic resin
Piston rod	non-rotating, chromium-plated steel, with flange (female piston rod) stainless steel upon request
Piston seal	nitrile rubber
Guide bush for piston rod	acetalic resin
Shock absorber seals	nitrile rubber
Magnet	standard supplied (stage 1)

### CODIFICATION KEY

R	T	2	2	0	0	3	2	0	6	0	0		
1	2	3	4	5	6	7	8						

### Comparison of overall dimensions

Stroke 300 mm (A)

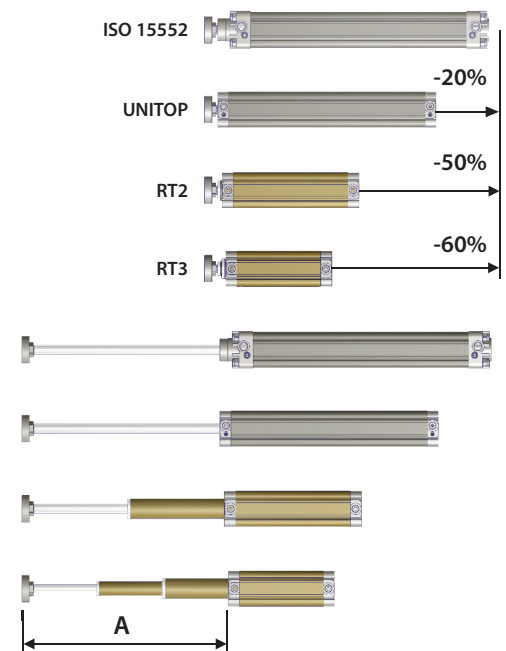

2 HIGH-TECH

1 Series	2 Rod	3 Stages	4 Type
RT = Ø 25÷63 mm - 2/3 Stage Telescopic Pneumatic Cylinders (with non-rotating piston rod and elastic shock absorber seals)	1 = Stainless steel piston rod 2 = Chromium-plated steel piston rod	2 = 2 stages 3 = 3 stages	0 = D.A. Female piston rod 3 = D.A. Male piston rod  D.A. = Double acting

5 Bore (mm)	6 Stroke (mm)	7 Option	8 Atex option
<b>2 stages</b> 025 = Ø25    032 = Ø32    040 = Ø40    050 = Ø50    063 = Ø63 <b>3 stages</b> 040 = Ø40    050 = Ø50    063 = Ø63	<b>2 stages</b> 0100 - 0120 - 0160 - 0180 - 0200 - 0300 - 0400 - 0500 0600 - 0700 - 0800 - 0900 - 1000 - 1100 - 1200 Max stroke: 0300 (Ø25)    0900 (Ø50) 0400 (Ø32)    1200 (Ø63) 0600 (Ø40)	I = Without flange (only for female piston rod) L = Freely rotating piston rod (without flange) M = With telescopic magnetic shaft (stage 2-3) except for Ø 25, only for female piston rod	X = Atex (upon request) <b>For types and versions, see ATEX catalogue</b>
	<b>3 stages</b> 0150 - 0180 - 0210 - 0240 - 0270 - 0300 - 0360 - 0450 0600 - 0750 - 900 - 1050 - 1200 - 1500 - 1800 Max stroke: 1200 (Ø40) 1500 (Ø50) 1800 (Ø63)		

Bore combinations

Ø	Ø		
	1 stage	2 stages	3 stages
25	25	16	-
32	32	20	-
40	40	25	16
50	50	32	20
63	63	40	25

Stroke tolerances Maximum torque (Nm)  
for non-rotating rod

Ø	Tolerance		Torque	
	mm		Nm	
	2 stages	3 stages	2 stages	3 stages
25	+2 - 0	+4 - 0	0,5	-
32	+3,2 - 0	+4 - 0	0,8	-
40	+3,2 - 0	+4 - 0	1	0,5
50	+3,2 - 0	+4 - 0	2	0,8
63	+3,2 - 0	+4 - 0	3	1

2-stage telescopic cylinders

Theoretical forces (N) at a certain working pressure (bar)

Ø	Surface area		Working pressure									
	mm <sup>2</sup>		bar									
	Thrust	Traction	Thrust					Traction				
			2	4	6	8	10	2	4	6	8	10
25	201	111	41	82	123	164	205	22	43	65	87	108
32	314	201	64	128	192	256	320	41	82	123	164	205
40	490	377	100	200	300	400	500	77	154	231	308	384
50	804	603	164	328	492	656	820	123	246	369	492	615
63	1256	1055	256	512	769	1025	1281	215	430	649	861	1076

2

3-stage telescopic cylinders

Theoretical forces (N) at a certain working pressure (bar)

Ø	Surface area		Working pressure									
	mm <sup>2</sup>		bar									
	Thrust	Traction	Thrust					Traction				
			2	4	6	8	10	2	4	6	8	10
40	201	111	41	82	123	164	205	22	43	65	87	108
50	314	201	64	128	192	256	320	41	82	123	164	205
63	490	377	100	200	300	400	500	77	154	231	308	384

Mass 2-stage cylinder RT220/RT220I/RT220M/RT223

Ø	Cylinder - stroke 0				Increase per mm stroke for 1/2 stroke				Moving element - stroke 0				Increase for mm stroke for 1/2 stroke			
	g				g				g				g			
	RT220	RT220I	RT220M	RT223	RT220	RT220I	RT220M	RT223	RT220	RT220I	RT220M	RT223	RT220	RT220I	RT220M	RT223
25	232	206	-	230	2,02	2,02	-	2,02	75	68	-	80	1,02	1,02	-	1,02
32	252	228	254	250	3,00	3,00	3,01	3,00	125	100	138	130	1,38	1,38	1,39	1,38
40	377	342	379	364	3,74	3,74	3,75	3,74	182	143	189	173	1,59	1,59	1,60	1,59
50	597	540	599	585	5,20	5,20	5,21	5,20	314	246	318	291	2,52	2,52	2,53	2,52
63	913	819	915	870	6,31	6,31	6,32	6,31	480	385	487	430	2,70	2,70	2,71	2,70

Mass 3-stage cylinder RT230/RT230I/RT230M/RT233

Ø	Cylinder - stroke 0				Increase per mm stroke for 1/3 stroke				Moving element - stroke 0				Increase for mm stroke for 1/3 stroke			
	g				g				g				g			
	RT230	RT230I	RT230M	RT233	RT230	RT230I	RT230M	RT233	RT230	RT230I	RT230M	RT233	RT230	RT230I	RT230M	RT233
40	367	337	369	362	3,88	3,88	3,90	3,88	162	137	191	168	1,73	1,73	1,75	1,73
50	510	486	512	511	5,00	5,00	5,02	5,00	265	226	307	257	2,32	2,32	2,34	2,32
63	810	775	812	810	6,32	6,32	6,34	6,32	417	349	459	380	2,71	2,71	2,73	2,71

Precautions for use and assembly

The telescopic cylinder works in optimal conditions when the load is axial, i.e. with the cylinder placed vertically, upwards and downwards.

Naturally it can horizontally and cantilevered. However in this case:

- the maximum strokes have to be reduced by 50% as compared to the maximum rated ones;
- request cylinders with slide units;
- the radial load has to be supported by other systems (carriage, slides, sliding guides);
- max. speed 0,5m/sec is recommended.

Fixing elements and accessories

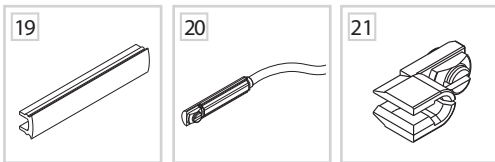
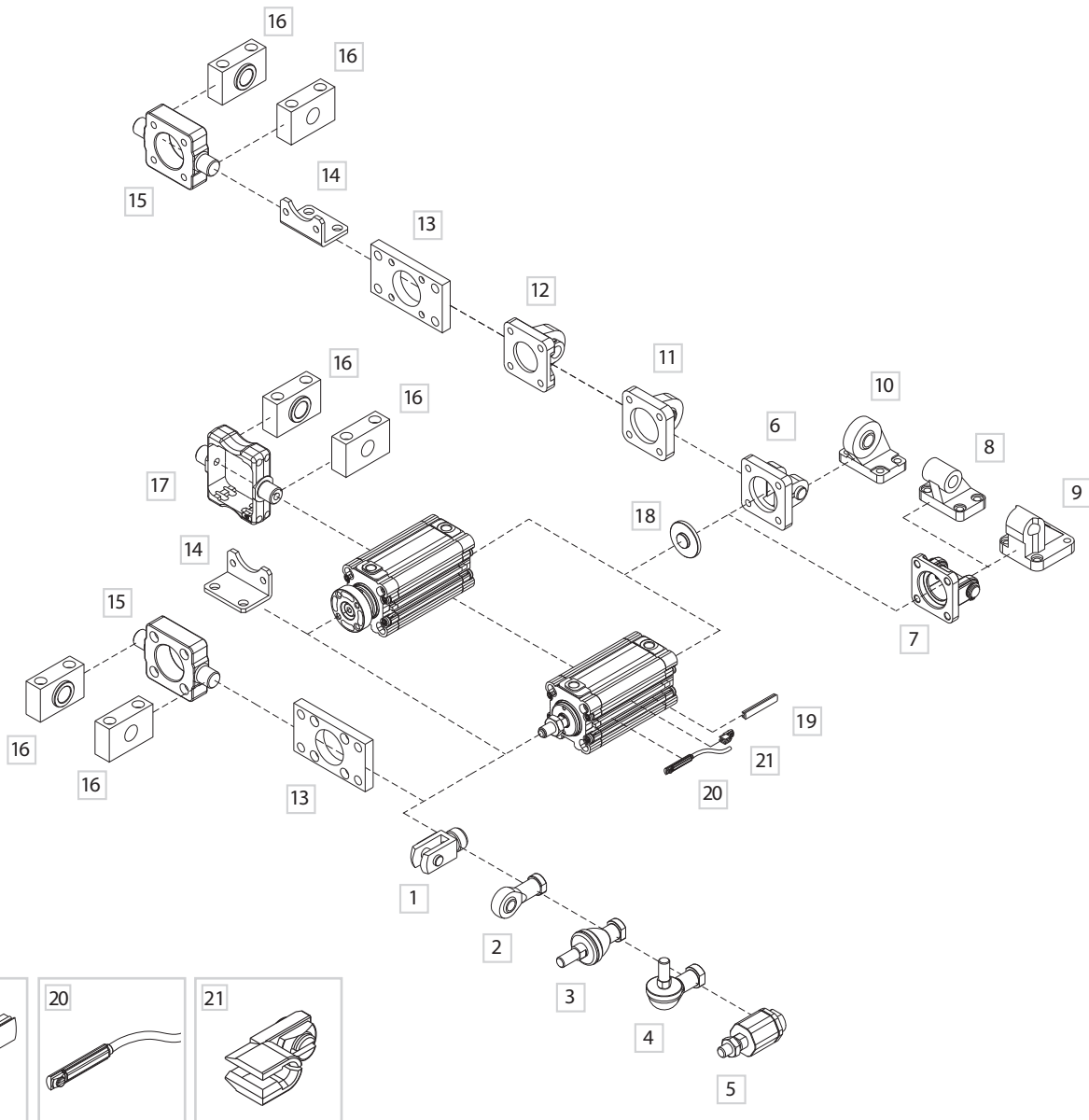

DESCRIPTION	PART NO.
1 Female fork with clips	KF-15_ _ _
2 Articulated self-lubricating fork	KF-17_ _ _
3 Fork with axially mounted articulated pin	KF-22_ _ _
4 Fork with angle-mounted articulated pin	KF-23_ _ _
5 Floating joint	KF-24_ _ _
6 Female hinge with pin	KF-10_ _ _ A
7 Narrow female hinge with pin	KF-10_ _ _ AS
8 Counter hinge 90° (AB7)	KF-19_ _ _ CTA
9 Counter hinge 90°	KF-19_ _ _
10 Articulated counter hinge	KF-19_ _ _ SC
11 Male hinge with articulated head	KF-11_ _ _ S
12 Rear male hinge	KF-11_ _ _
13 Front/rear flange	KF-12_ _ _
14 Angle bracket	KF-13_ _ _
15 Front/rear hinge with floating pin	KF-14_ _ _ AP
16 Hinge support	KF-41_ _ _
17 ISO intermediate hinge	KDF-14_ _ _ /RPF-14_ _ _
18 Centering adaptor ring	RSF-09_ _ _
19 DHF covering strip	DHF-0020100
20 DF sensor	DF- _ _ _
21 Cable clamping for DF sensor	DF-001

2 stages with flange RT220...

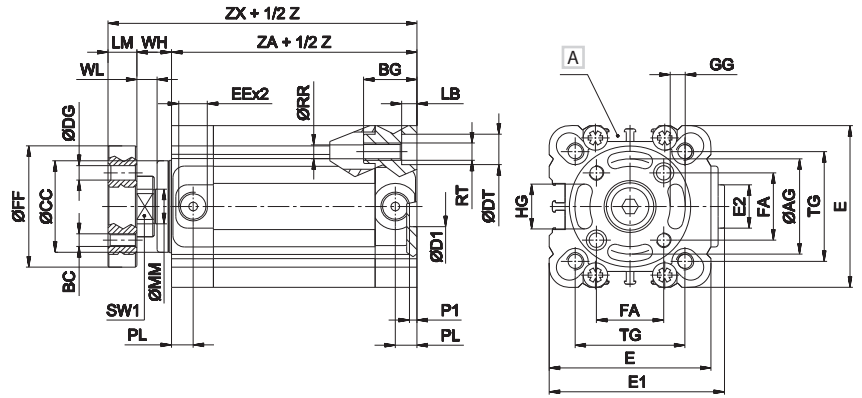
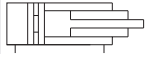

2 stages with flange, magnetic version RT220...M

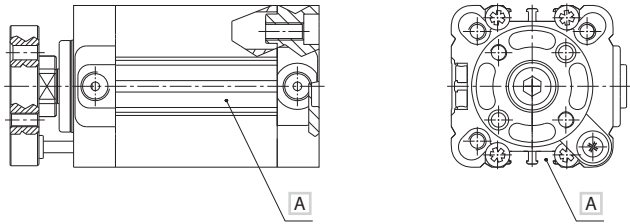
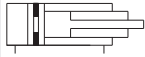

A = the magnetic sensor DF... may only be placed near the telescopic magnet holder stem (as shown in the drawing)

2 stages, female piston rod RT220...

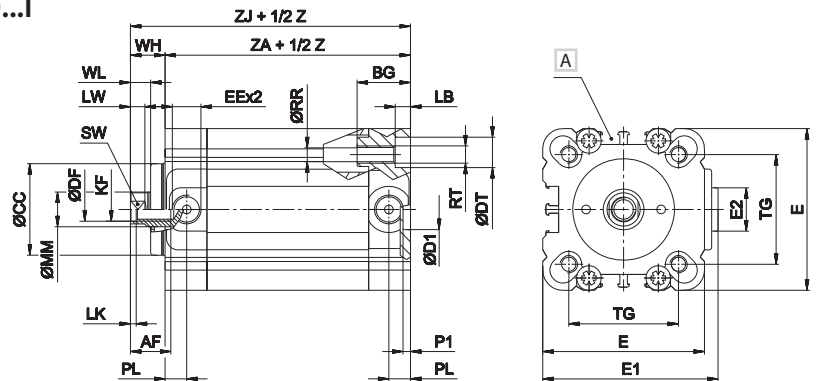
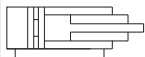

2 stages, male piston rod RT223...

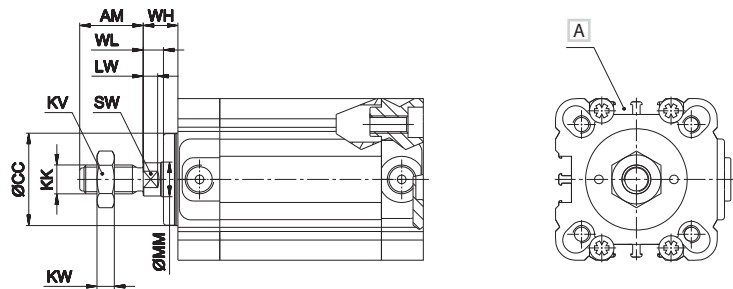
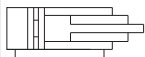
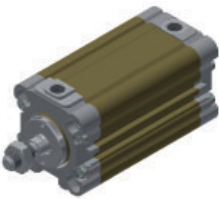

A Groove for sensor

Z = Stroke

Ø	AF	AG	AM	BC	BG	CC	DF	DG	DT	D1 H11	E	E1	E2	EE	FA	FF	GG	HG	KF	KK
25	10	22	22	M5	16	22	6,1	5	8	2	37	39	18	M5	15,6	30	5	9	M6	M10x1,25
32	12	28	22	M5	18	26	8,2	5	9	14	46	50,5	16	G1/8	19,8	37	5,2	11	M8	M10x1,25
40	12	33	22	M5	18	32	8,2	5	9	14	56	60,5	16	G1/8	23,3	42	5,2	15	M8	M10x1,25
50	16	42	24	M6	24	40	10,2	6	11	18	66	70,5	16	G1/8	29,7	52	6,2	19	M10	M12x1,25
63	16	50	24	M6	24	48	10,2	6	11	18	79	83,5	38	G1/8	35,4	64	6,2	25	M10	M12x1,25
Ø	KV	KW	LB	LK	LM	LW	MM	PL	P1	RR	RT	SW	SW1	TG	WH	WL	ZA	ZJ	ZX	
25	17	3	4,5	1	8	4,5	10	8	8	4,2	M5	8	-	26	17	7	48	65	73	
32	17	4	5,3	2	10	5	12	7,5	2,5	5,2	M6	10	17	32,5	13	7	58	71	81	
40	17	4	5,3	2	10	5	12	7,5	2,5	5,2	M6	10	19	38	12	7	60	72	82	
50	19	5	6,5	2	12	6	16	7,5	2,5	6,6	M8	13	24	46,5	15	8	61	76	88	
63	19	5	6,5	2	12	6	16	7,5	2,5	6,6	M8	13	24	56,5	15	8	65	80	92	

Female hinge with pin (ISO MP2)

> Standard version (with flange)

> Male piston rod version

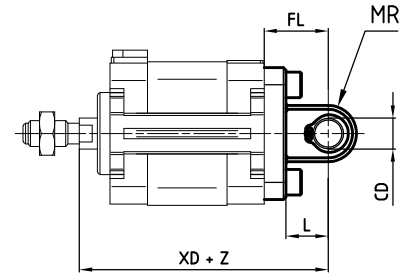
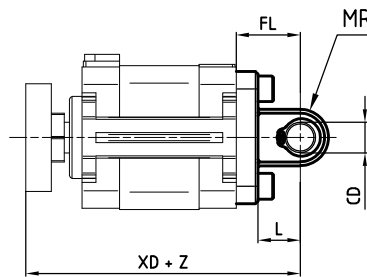
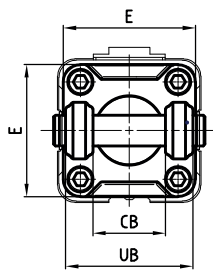
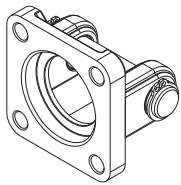

Material: Aluminium Z = Stroke

Ø	CB	CD	E	FL	L	MR	UB	XD (standard version)		XD (male piston rod version)		Mass g	Part no.
	H14	H9		± 0,2	min	Max		H14					
25	-	-	-	-	-	-	-	-	-	-	-	-	-
32	26	10	48	22	12	11	45	103	±1,25	93	±1,25	75	KF-10032A
40	28	12	54	25	15	13	52	107	±1,25	97	±1,25	110	KF-10040A
50	32	12	65	27	15	13	60	115	±1,25	103	±1,25	150	KF-10050A
63	40	16	75	32	20	17	70	124	±1,6	112	±1,6	270	KF-10063A

Counter hinge 90° (AB7)

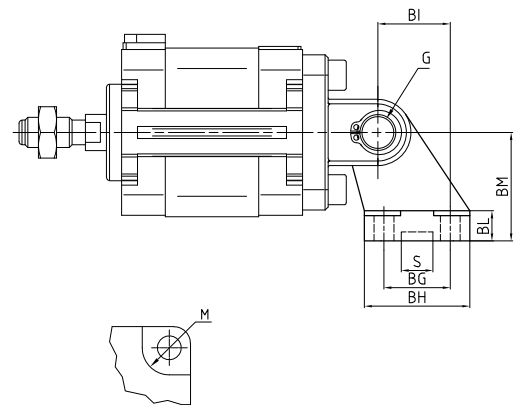
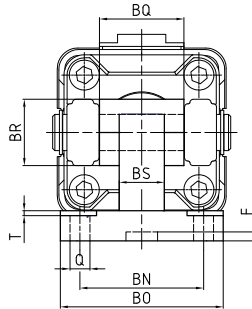
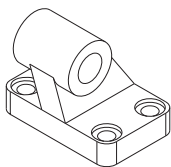

Material: Aluminium

Ø	Q	M	BG	BH	BI	BL	BM	BN	BO	BS	BR	T	G	S	F	BQ	Mass g	Part no.
	H13	H13	JS 14	Max	JS 14	JS 15	JS 14	Max	Max	Max	Max	H9	<sup>+0,5</sup> <sub>0</sub>	<sup>+0,5</sup> <sub>0</sub>				
25	-	-	-	-	-	-	-	-	-	-	-	-	-	-	-	-	-	-
32	6,6	11	18	31	21	8	32	38	51	10	20	1,6	10	10,5	3	26	56	KF-19032CTA
40	6,6	11	22	35	24	10	36	41	54	15	22	1,6	12	10,5	3	28	139	KF-19040CTA
50	9	15	30	45	33	12	45	50	65	16	26	1,6	12	10,5	3	32	142	KF-19050CTA
63	9	15	35	50	37	14	50	52	67	16	30	1,6	16	10,5	3	40	200	KF-19063CTA

Counter hinge 90°

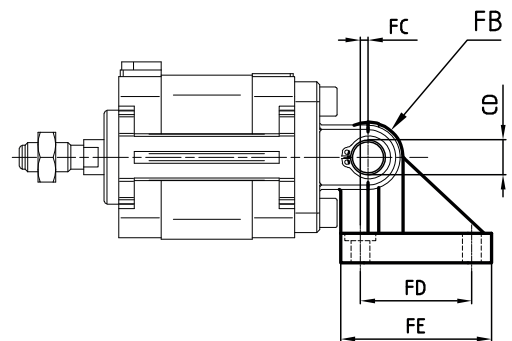
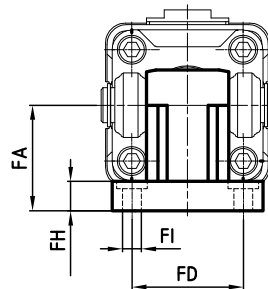
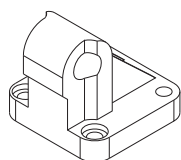

Material: Aluminium

Ø	CD	FA	FB	FC	FD	FE	FH	FI	Mass g	Part no.
	H9									
25	-	-	-	-	-	-	-	-	-	-
32	10	32	10	1,2	32,5	46,5	9	6,5	90	KF-19032
40	12	36	12	2,6	38	51,5	9	6,5	120	KF-19040
50	12	45	12	0,3	46,5	63,5	9	8,5	200	KF-19050
63	16	50	16	3,3	56,5	73	10,5	8,5	320	KF-19063

**Narrow female hinge with pin (DIN 648K)**

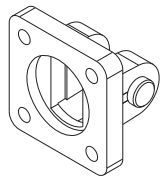

> Standard version (with flange)

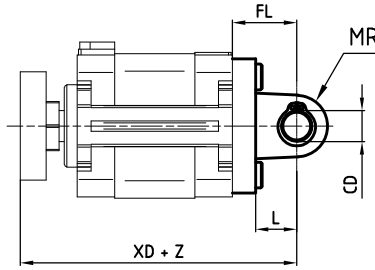
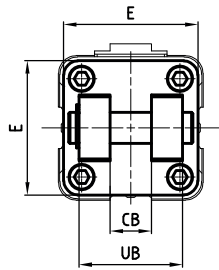

> Male piston rod version

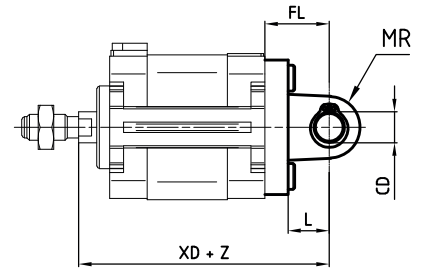

Material: Aluminium Z = Stroke

Ø	CB H14	CD H9	E	FL ± 0,2	L min	MR Max	UB H14	XD (standard version)	XD (male piston rod version)	Mass g	Part no.		
25	-	-	-	-	-	-	-	-	-	-	-		
32	14	10	45	22	13	10	34	103	±1,25	93	±1,25	68	KF-10032AS
40	16	12	52	25	16	12	40	107	±1,25	97	±1,25	112	KF-10040AS
50	21	16	65	27	16	14	45	115	±1,25	113	±1,25	196	KF-10050AS
63	21	16	75	32	21	18	51	124	±1,6	112	±1,6	288	KF-10063AS

**Articulated male rear hinge (ISO MP6)**

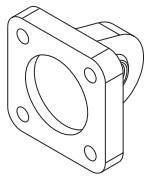

> Standard version (with flange)

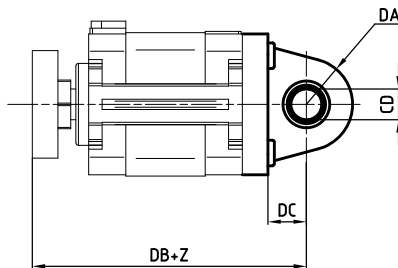
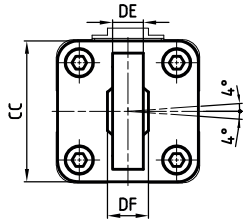

> Male piston rod version

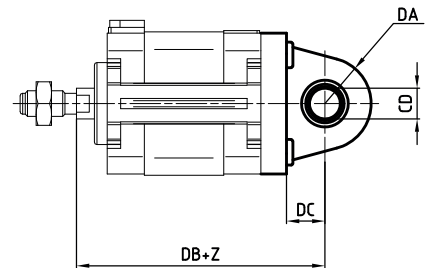

Material: Aluminium Z = Stroke

Ø	CC	CD H9	DA	DB (standard version)	DB (male piston rod version)	DC	DE	DF	Mass g	Part no.
25	-	-	-	-	-	-	-	-	-	-
32	48	10	15	115	95	14	10,5	14	100	KF-11032S
40	54	12	18	118,5	98,5	16,5	12	16	200	KF-11040S
50	65	12	20	129	105,5	17,5	12	16	300	KF-11050S
63	75	16	21	137,5	113,5	21,5	15	21	350	KF-11063S

**Articulated counter hinge (DIN 648K)**

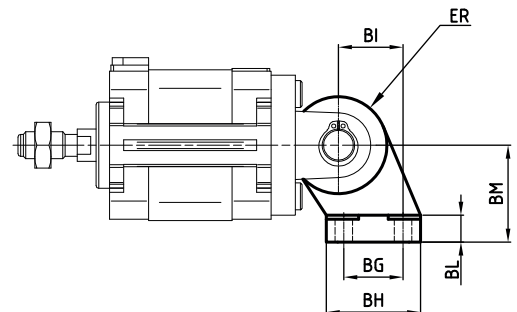
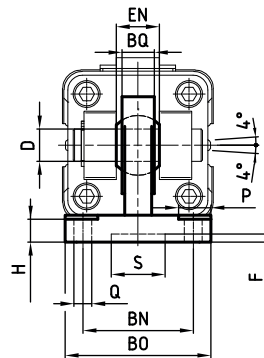
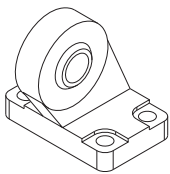

Material: Zinc-plated steel

Ø	Q H13	P H13	BG JS14	BH Max	BI JS15	BL	BM JS15	BN JS14	BO Max	EN -0,1	ER Max	BQ Max	D H7	H +0,5	S H13	F	Mass g	Part no.
25	-	-	-	-	-	-	-	-	-	-	-	-	-	-	-	-	-	-
32	6,6	11	18	31	21	10	32	38	51	14	15	10,5	10	8,5	20	3	178	KF-19032SC
40	6,6	11	22	35	24	10	36	41	54	16	18	12	12	8,5	20	3	268	KF-19040SC
50	9	15	30	45	33	12	45	50	65	21	20	15	16	10,5	20	3	458	KF-19050SC
63	9	15	35	50	37	12	50	52	67	21	23	15	16	10,5	20	3	550	KF-19063SC

Rear male hinge (ISO MP4)

> Standard version (with flange)

> Male piston rod version

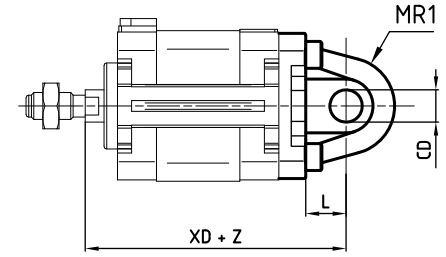
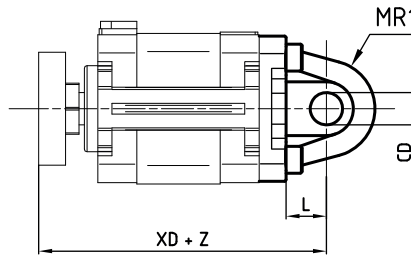
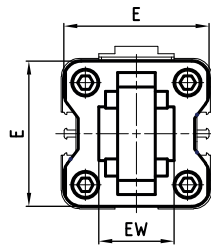
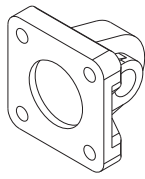

Material: Aluminium

Z = Stroke

Ø	CD H9	E	EW	L min	MR1 Max	XD (standard version)	XD (male piston rod version)	Mass g	Part no.
25	8	38	16 -0,2/-0,6	14	8	85 ±1,25	75 ±1,25	43	RPF-11025
32	10	48	26 -0,2/-0,6	12	15	113 ±1,25	103 ±1,25	80	KF-11032
40	12	54	28 -0,2/-0,6	15	18	117 ±1,25	107 ±1,25	100	KF-11040
50	12	65	32 -0,2/-0,6	15	20	127 ±1,25	125 ±1,25	170	KF-11050
63	16	75	40 -0,2/-0,6	20	23	136 ±1,6	124 ±1,6	250	KF-11063

Hinge support

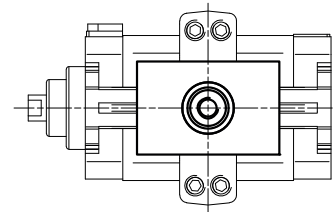
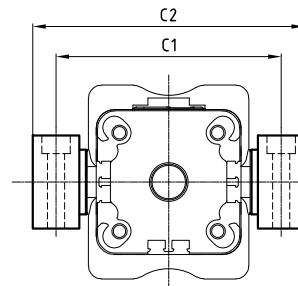
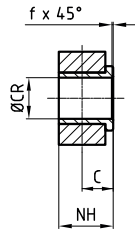
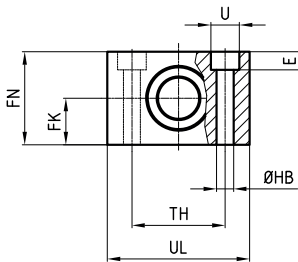
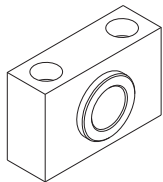

Material: Anodized aluminium and brass bushing

Ø	C	CR F7	FK ±0,1	FN	HB	NH	TH ±0,1	UL	U	E ±0,5	f	C1	C2	Mass g	Part no.
25	-	-	-	-	-	-	-	-	-	-	-	-	-	-	-
32	10,2	12	15	30	6,6	18	32	46	11	7	1	71	86	110	KF-41032
40	12	16	18	36	9	21	36	55	15	9	1,6	87	105	200	KF-41040050
50	12	16	18	36	9	21	36	55	15	9	1,6	99	117	200	KF-41040050
63	13	20	20	40	11	23	42	65	18	11	1,6	116	136	267	KF-41063080

Angle bracket

> Standard version (with flange)

> Male piston rod version

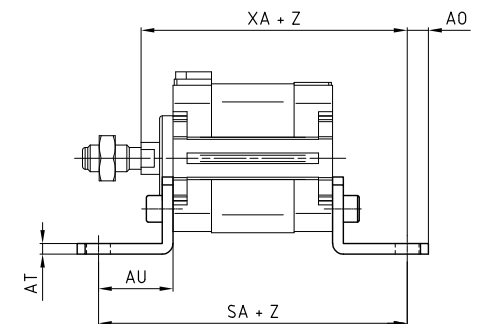
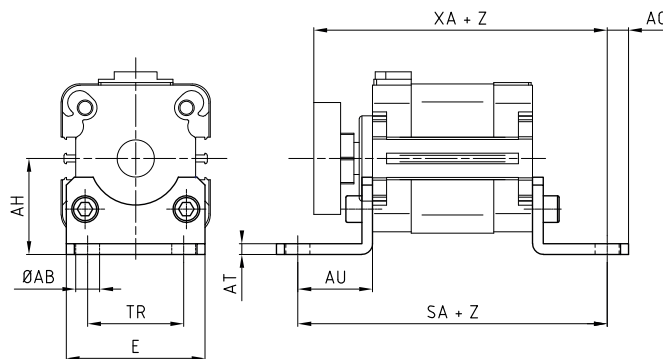
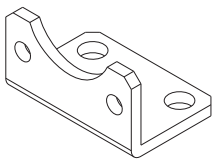

Material: Zinc-plated steel

Z = Stroke

Ø	Ø AB Ø h13	AH Js15	AO	AT	AU ±0,2	E Max	SA	TR	XA	Mass g	Part no.
25	6,6	30	6	4	16	40	80	26	89	40	RTF-13025
32	7	32	11	4	24	50	106	32	105	70	KF-13032
40	9	36	15	4	28	58	116	36	110	100	KF-13040
50	9	45	15	5	32	70	125	45	120	150	KF-13050
63	9	50	15	5	32	85	129	50	124	250	KF-13063

ISO intermediate hinge

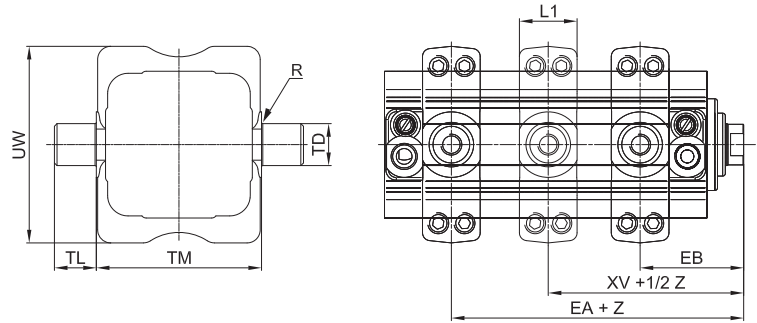
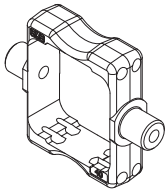

Material: Zinc-plated steel

Z = Stroke

Ø	EA Max	EB min	L1 Max	R Max	TD e9	TL h14	TM h14	UW Max	XV	Mass g	Part No.
25	-	-	-	-	-	-	-	-	-	-	-
32	24	34	22	0,5	12	12	50	65	29	130	KDF-14032
40	25	34	22	0,5	16	16	63	75	29,5	240	RPF-14040
50	26	35	22	1	16	16	75	95	30,5	320	RPF-14050
63	27	38	28	1	20	20	90	105	32,5	470	RPF-14063



Front/rear flange

> Front/rear assembly Ø25 mm

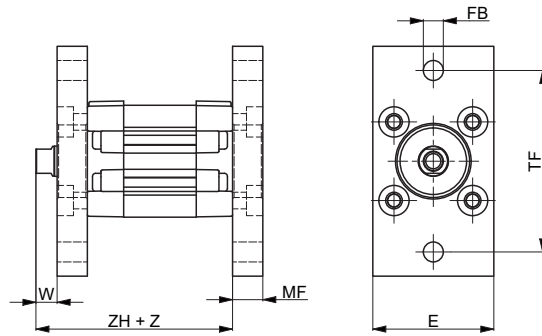
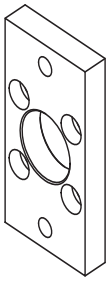

> Front assembly Ø32 ÷ 63 mm

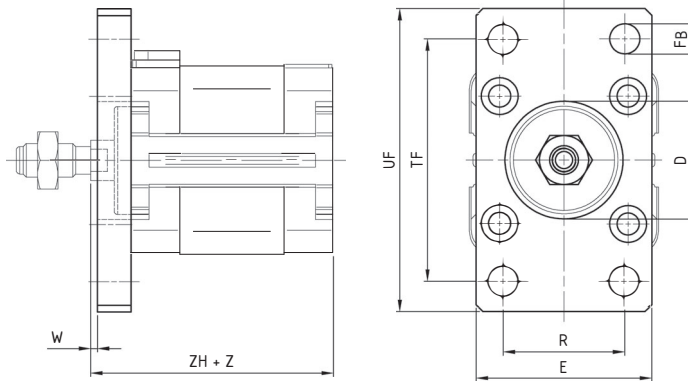
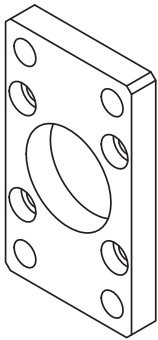

> Rear assembly Ø32 ÷ 63 mm

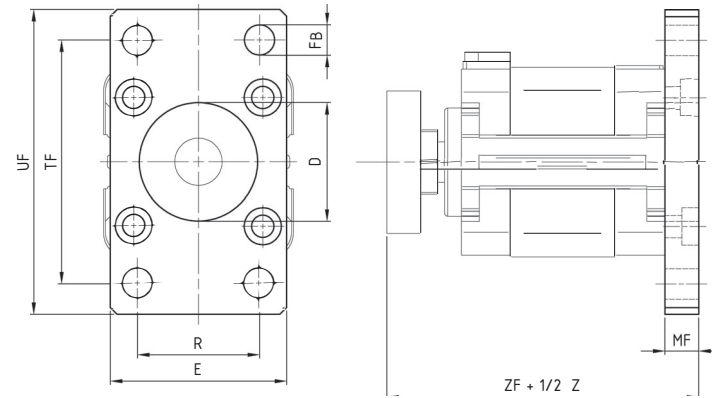

Material: Zinc-plated steel

Z = Stroke

Ø	ØD h11	E	ØFB h13	MF	R Js14	TF Js14	UF	W	ZF	ZH	Mass g	Part No.
25	24	40	6,6	10	-	60	76	7	83	58	180	RTF-12025
32	30	45	7	10	32	64	80	3	91	68	200	KF-12032
40	35	52	9	10	36	72	90	2	92	70	250	KF-12040
50	44	65	9	12	45	90	110	3	100	73	500	KF-12050
63	52	75	9	12	50	100	120	3	104	77	650	KF-12063

Female fork with clips

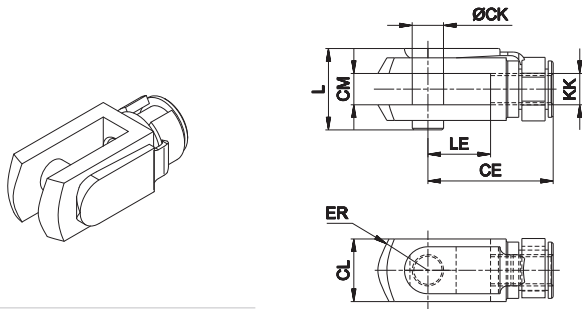

Material: Zinc-plated steel

Cylinder Ø	CE	CK	CL	CM	ER	KK	L	LE	Mass g	Part no.
25-32-40	40	10	20	10	16	M10x1,25	26	20	90	KF-15032
50-63	48	12	24	12	19	M12x1,25	32	24	150	KF-15040

Fork with pin suitable for piston rod according to ISO 8140 standard

Articulated self-lubricating fork

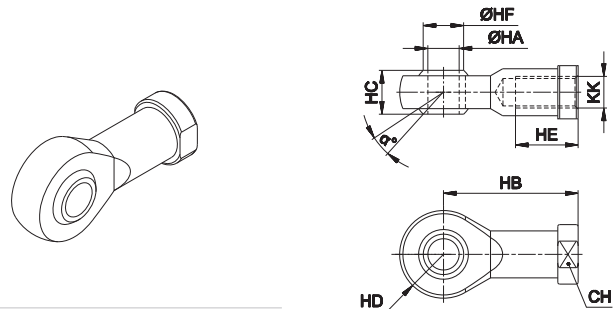

Material: Zinc-plated steel

Cylinder Ø	α°	CH	KK	HA	HB	HC	HD	HE	HF	Mass g	Part no.
25-32-40	13	17	M10x1,25	10	43	14	14	20	12,9	76	KF-17032
50-63	13	19	M12x1,25	12	50	16	16	22	15,4	110	KF-17040

Fork with axially mounted articulated pin

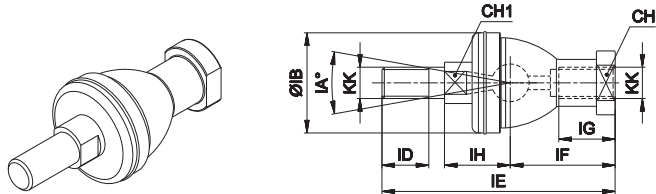

Material: Zinc-plated steel

Cylinder Ø	CH	CH1	IA°	KK	IH	IB	ID	IE	IF	IG	Mass g	Part no.
25-32-40	17	11	30	M10x1,25	19,5 ±0,3	32	15	74,5	35	18	120	KF-22025
50-63	19	17	30	M12x1,25	22	36	17	84	40	20	185	KF-22040

Fork with angle mounted articulated pin

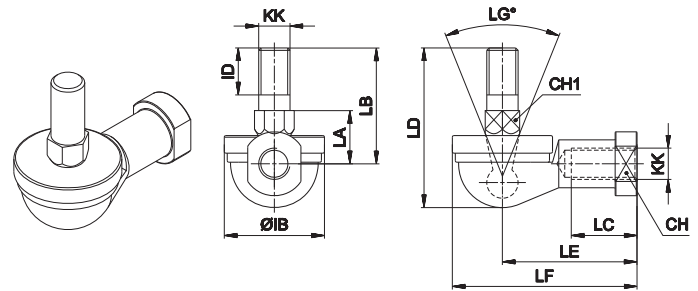

Material: Zinc-plated steel

Cylinder Ø	CH	CH1	LG°	KK	IB	ID	LA	LB	LC	LD	LE	LF	Mass g	Part no.
25-32-40	17	11	50	M10x1,25	32	15	17	37	21	50,5	43	57	110	KF-23025
50-63	19	17	50	M12x1,25	36	17	19	42	27	57,5	50	66	165	KF-23040

Floating joint

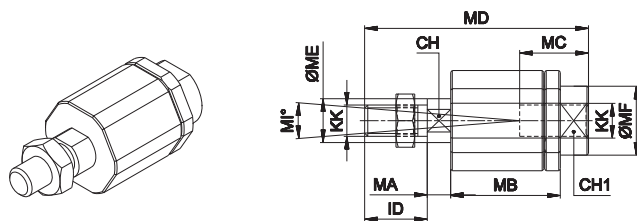

Material: Zinc-plated steel

Cylinder Ø	CH	CH1	ID	KK	MA	MB	MC	MD	ME	MF	MG	MH	MI°	Mass g	Part no.
25-32-40	12	19	71	M10x1,25	5	35	20	71	14	22	30	32	8	220	KF-24032
50-63	12	19	75	M12x1,25	5	35	20	75	14	22	30	32	8	230	KF-24040

Piston rod locknut (zinc-plated steel)

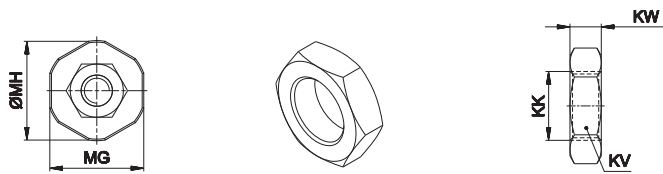

Material: Zinc-plated steel

Cylinder Ø	KK	KV	KW	Mass g	Part no.
25-32-40	M10x1,25	17	6	5	KF-16032
50-63	M12x1,25	19	7	10	KF-16040

3 stages with flange RT230...

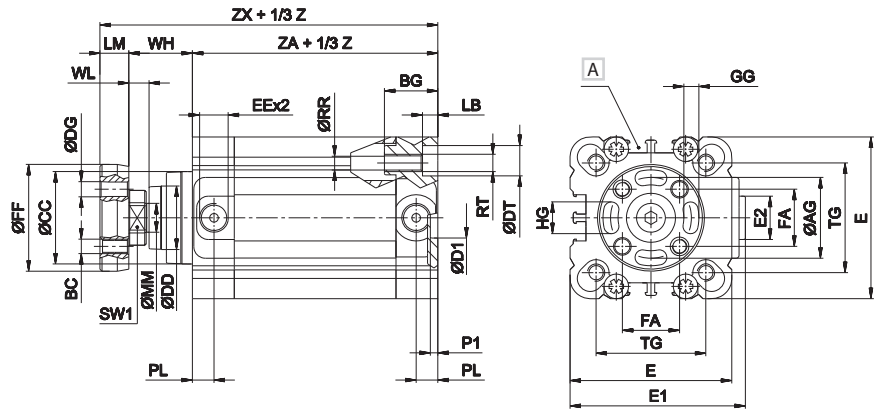
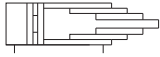
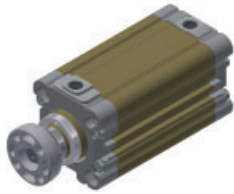

3 stages, magnetic version RT230...M

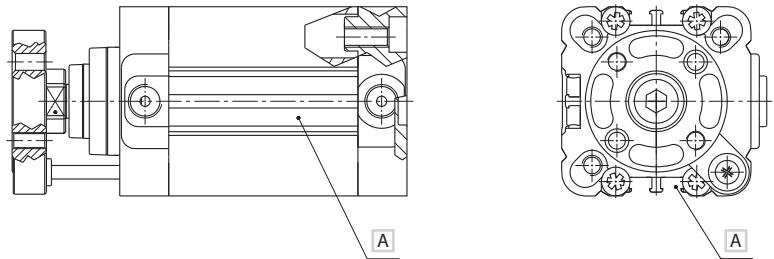
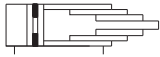
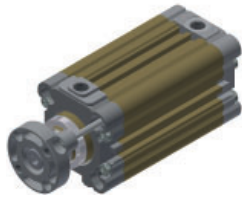

A = the magnetic sensor DF... may only be placed near the telescopic magnet holder stem (as shown in the drawing).

3 stages, female piston rod RT230...I

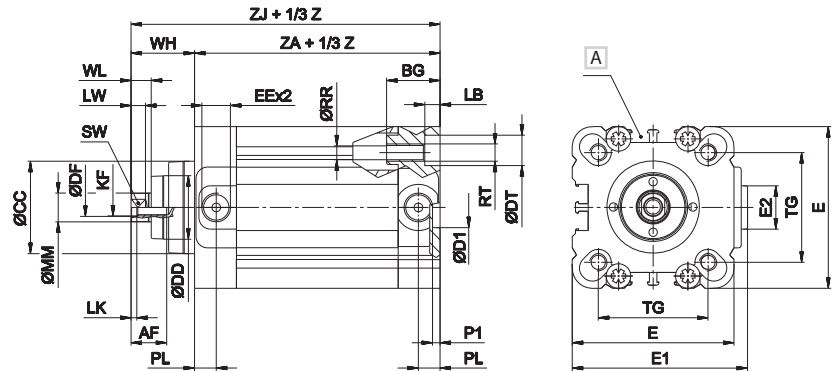

3 stages, male piston rod RT233...

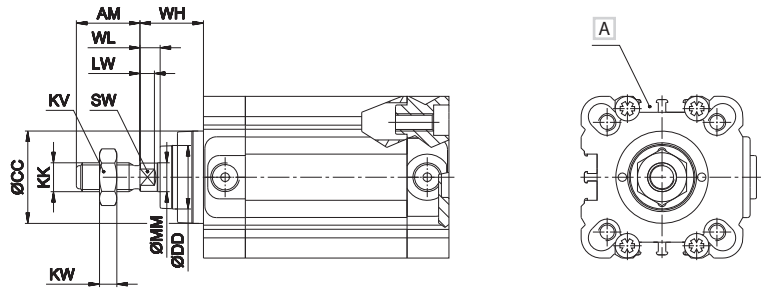
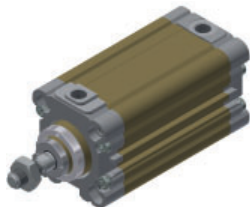

A Groove for sensor

Z = Stroke

Ø	AF	AG	AM	BC	BG	CC	DF	DG	DT	D1	E	E1	E2	EE	FA	FF	GG	HG	KF	KK	KV	KW	LB	LK	LM
40	12	33	22	M5	18	32	8,2	5	9	14	56	60,5	16	G1/8	23,3	42	5,2	15	M8	M10x1,25	17	4	5,3	2	10
50	16	42	24	M6	24	40	10,2	6	11	18	66	70,5	16	G1/8	29,7	52	6,2	19	M10	M12x1,25	19	5	6,5	2	12
63	16	50	24	M6	24	48	10,2	6	11	18	79	83,5	38	G1/8	35,4	64	6,2	25	M10	M12x1,25	19	5	6,5	2	12

Dimensional variations for RT230...M series

Ø	LW	MM	PL	P1	RR	RT	SW	SW1	TG	WH	WL	ZA	ZJ	ZX	Ø	AG	BC	DG	FA	FF	GG	HG	LM	SW2	ZX
40	5	12	7,5	2,5	5,2	M6	10	19	38	12	7	60	72	82	40	5	12	7,5	2,5	5,2	M6	10	19	38	12
50	6	16	7,5	2,5	6,6	M8	13	24	46,5	15	8	61	76	88	50	6	16	7,5	2,5	6,6	M8	13	24	46,5	15
63	6	16	7,5	2,5	6,6	M8	13	24	56,5	15	8	65	80	92	63	6	16	7,5	2,5	6,6	M8	13	24	56,5	15

Female hinge with pin (ISO MP2)

> Standard version (with flange)

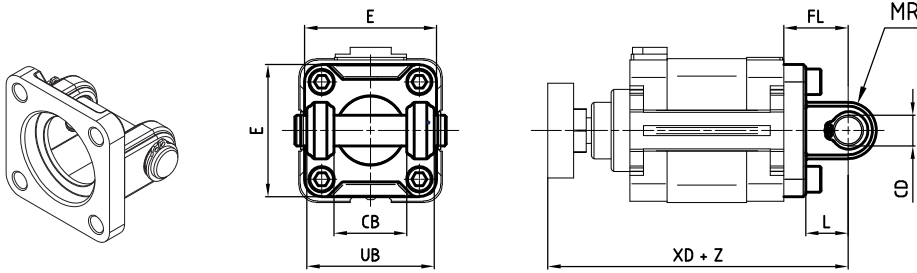

> Male piston rod version

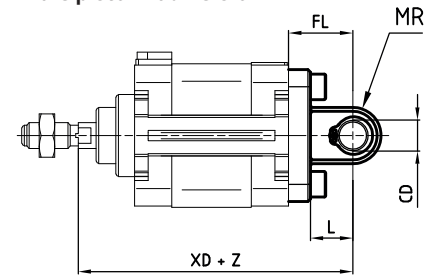

Material: Aluminium

Z = Stroke

Ø	CB	CD	E	FL	L	MR	UB	XD (standard version)		XD (male piston rod version)		Mass g	Part no.
	H14	H9		± 0,2		Max	H14						
40	28	12	54	25	15	13	52	107	±1,25	97	±1,25	110	KF-10040A
50	32	12	65	27	15	13	60	115	±1,25	103	±1,25	150	KF-10050A
63	40	16	75	32	20	17	70	124	±1,6	112	±1,6	270	KF-10063A

Counter hinge 90° (AB7)

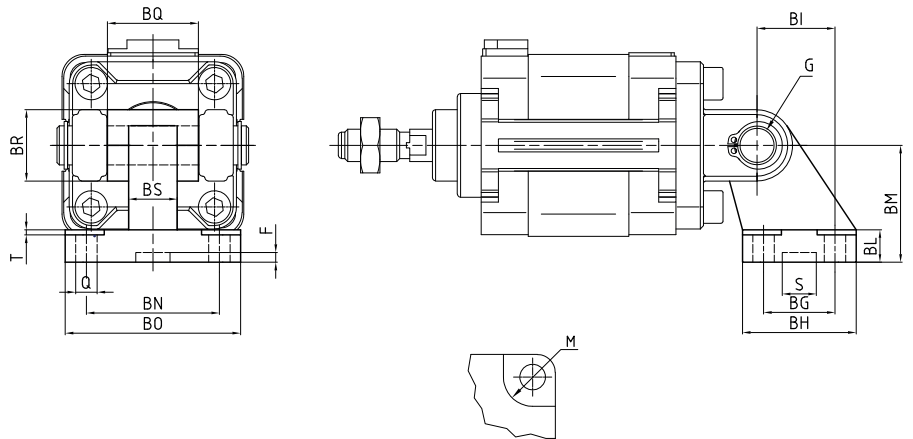
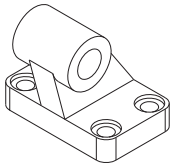

Material: Aluminium

Ø	Q	M	BG	BH	BI	BL	BM	BN	BO	BS	BR	T	G	S	F	BQ	Mass g	Part no.	
	H13	H13	JS 14	Max	JS 14	JS 15	JS 14	Max	Max	Max	Max	H9	<sup>+0,5</sup> <sub>0</sub>	<sup>+0,5</sup> <sub>0</sub>					
40	6,6	11	22	35	24	10	36	41	54	15	22	1,6	12	10,5	3	28	+0,2 -0,6	139	KF-19040CTA
50	9	15	30	45	33	12	45	50	65	16	26	1,6	12	10,5	3	32		142	KF-19050CTA
63	9	15	35	50	37	14	50	52	67	16	30	1,6	16	10,5	3	40		200	KF-19063CTA

Counter hinge 90°

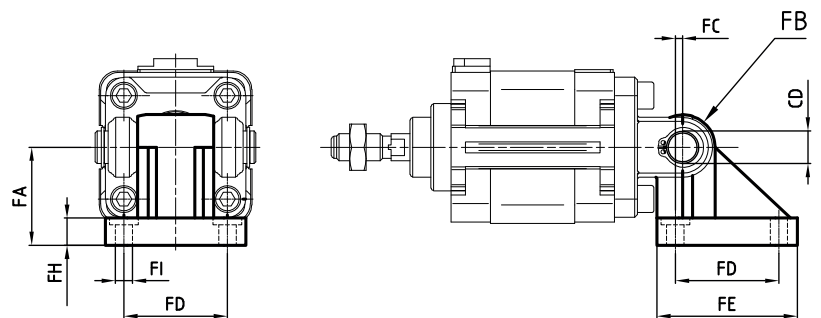
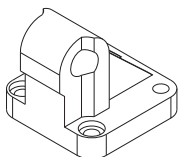

Material: Aluminium

Ø	CD	FA	FB	FC	FD	FE	FH	FI	Mass g	Part no.
	H9									
40	12	36	12	2,6	38	51,5	9	6,5	120	KF-19040
50	12	45	12	0,3	46,5	63,5	9	8,5	200	KF-19050
63	16	50	16	3,3	56,5	73	10,5	8,5	320	KF-19063

**Narrow female hinge with pin (DIN 648K)**

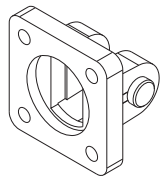

> Standard version (with flange)

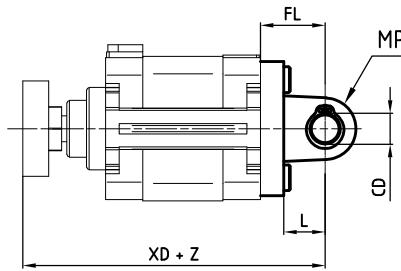
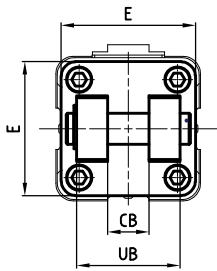

> Male piston rod version

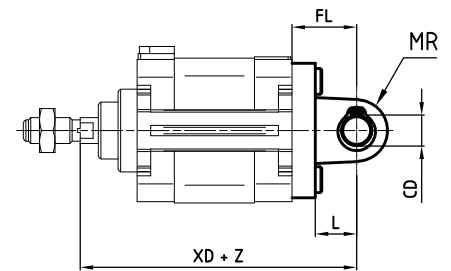

Material: Aluminium Z = Stroke

Ø	CB H14	CD H9	E	FL ± 0,2	L min	MR Max	UB H14	XD (standard version)	XD (male piston rod version)	Mass g	Part no.
40	16	12	52	25	16	12	40	107 ±1,25	97 ±1,25	112	KF-10040AS
50	21	16	65	27	16	14	45	115 ±1,25	103 ±1,25	196	KF-10050AS
63	21	16	75	32	21	18	51	124 ±1,6	112 ±1,6	288	KF-10063AS

**Articulated male rear hinge (ISO MP6)**

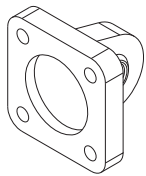

> Standard version (with flange)

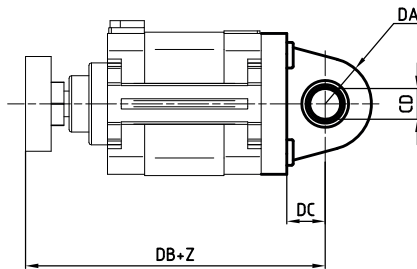
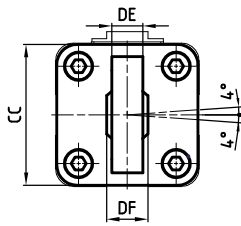

> Male piston rod version

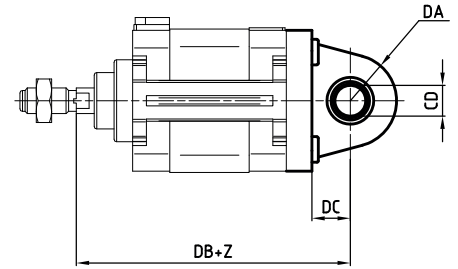

Material: Aluminium Z = Stroke

Ø	CC	CD H9	DA	DB (standard version)	DB (male piston rod version)	DC	DE	DF	Mass g	Part no.
40	54	12	18	107	97	16,5	12	16	200	KF-11040S
50	65	12	20	115	103	17,5	12	16	300	KF-11050S
63	75	16	21	124	112	21,5	15	21	350	KF-11063S

**Articulated counter hinge (DIN 648K)**

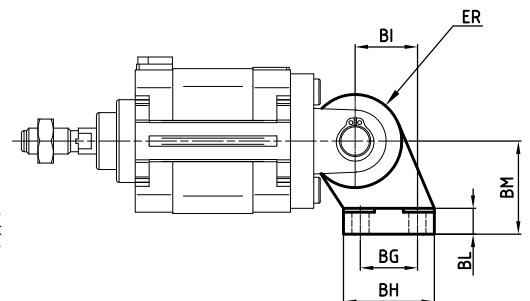
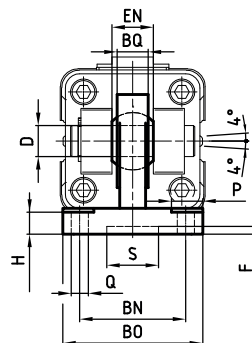
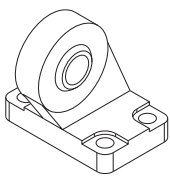

Material: Zinc-plated steel

Ø	Q H13	P H13	BG JS14	BH Max	BI JS15	BL	BM JS15	BN JS14	BO Max	EN 0,1	ER Max	BQ Max	D H7	H +0,5	S H13	F	Mass g	Part no.
40	6,6	11	22	35	24	10	36	41	54	16	18	12	12	8,5	20	3	268	KF-19040SC
50	9	15	30	45	33	12	45	50	65	21	20	15	16	10,5	20	3	458	KF-19050SC
63	9	15	35	50	37	12	50	52	67	21	23	15	16	10,5	20	3	550	KF-19063SC

Rear male hinge (ISO MP4)

> Standard version (with flange)

> Male piston rod version

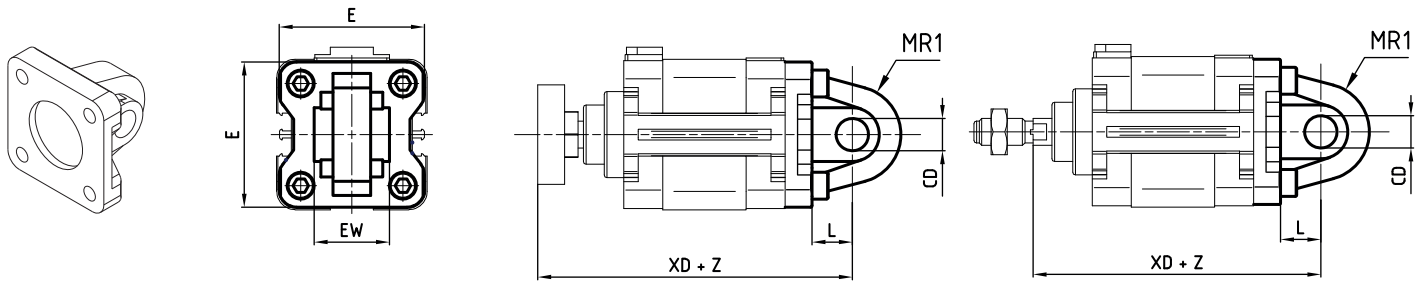

Material: Aluminium

Z = Stroke

Ø	CD H9	E	EW	L min	MR1 Max	XD (standard version)		XD (male piston rod version)		Mass g	Part no.	
							±		±			
40	12	54	28	-0,2/-0,6	15	18	107	±1,25	97	±1,25	100	KF-11040
50	12	65	32	-0,2/-0,6	15	20	115	±1,25	103	±1,25	170	KF-11050
63	16	75	40	-0,2/-0,6	20	23	124	±1,6	112	±1,6	250	KF-11063

Hinge support

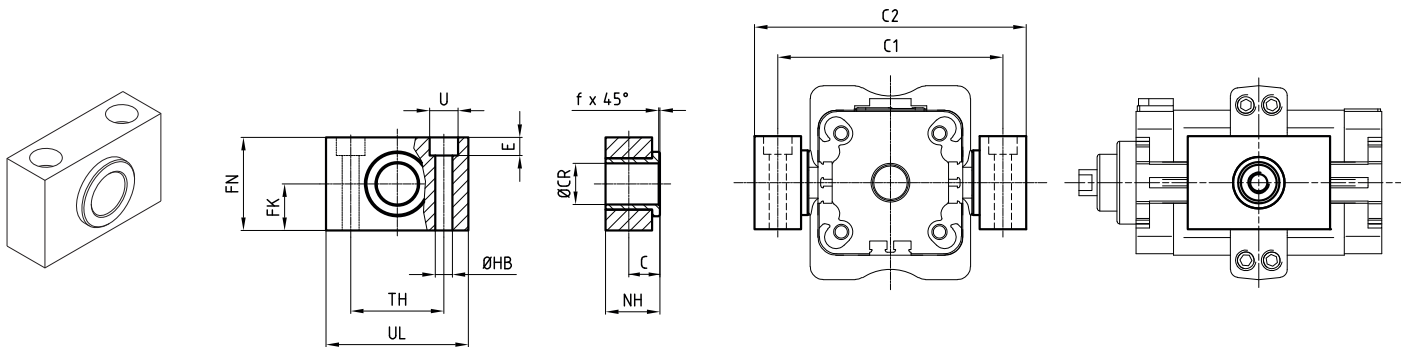

Material: Anodized aluminium and brass bushing

Ø	C	CR F7	FK ±0,1	FN	HB	NH	TH ±0,1	UL	U	E ±0,5	F	C1	C2	Mass g	Part no.
50	12	16	18	36	9	21	36	55	15	9	1,6	99	117	200	KF-41040050
63	13	20	20	40	11	23	42	65	18	11	1,6	116	136	267	KF-41063080

Angle bracket

> Standard version (with flange)

> Male piston rod version

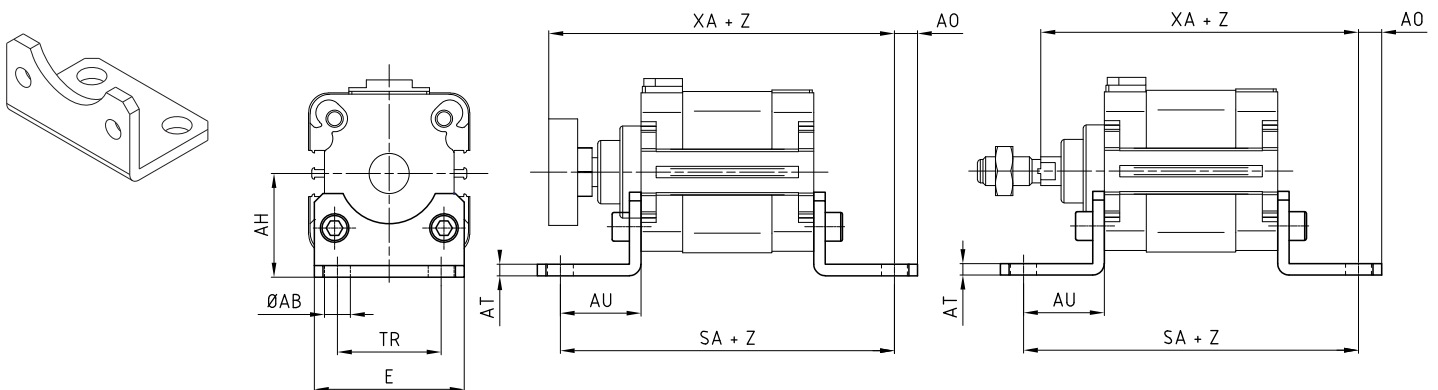

Material: Zinc-plated steel

Z = Stroke

Ø	Ø AB Ø h13	AH Js15	AO	AT	AU ±0,2	E Max	SA	TR	XA	Mass g	Part no.
50	9	45	15	5	32	70	125	45	120	150	KF-13050
63	9	50	15	5	32	85	129	50	124	250	KF-13063

ISO intermediate hinge

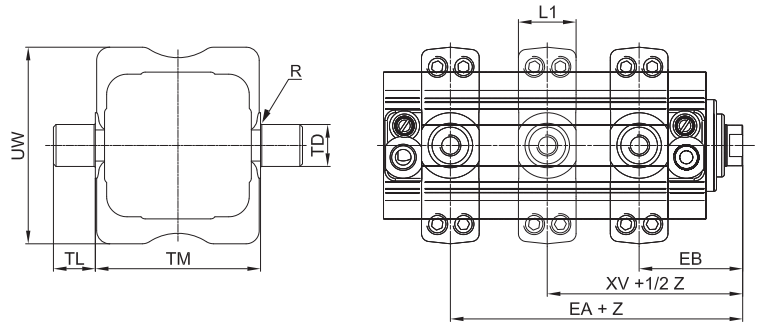
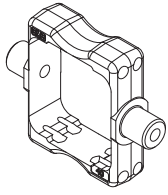

Material: Zinc-plated steel

Ø	EA	EB	L1	R	TD	TL	TM	UW	XV	Mass	Part no.
	Max	min	Max	Max	e9	h14	h14	Max	Max		
40	25	34	22	0,5	16	16	63	75	29,5	268	KF-19040SC
50	26	35	22	1	16	16	75	95	30,5	458	KF-19050SC
63	27	38	28	1	20	20	90	105	32,5	550	KF-19063SC

Front/rear flange

> Front assembly

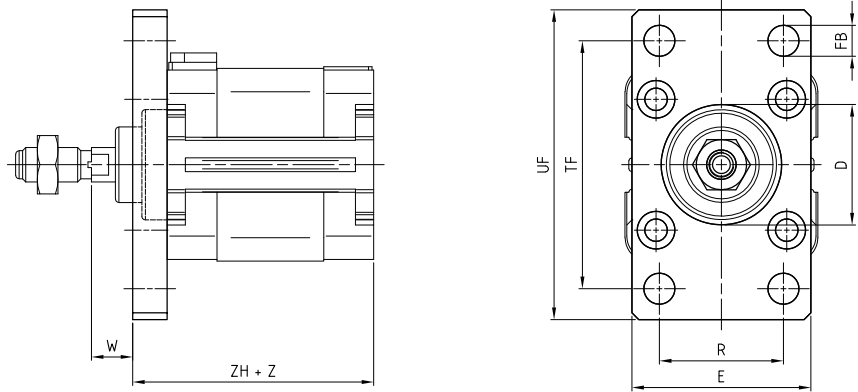
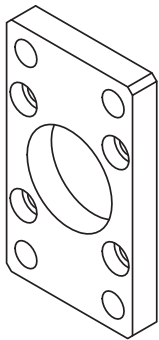

> Rear assembly

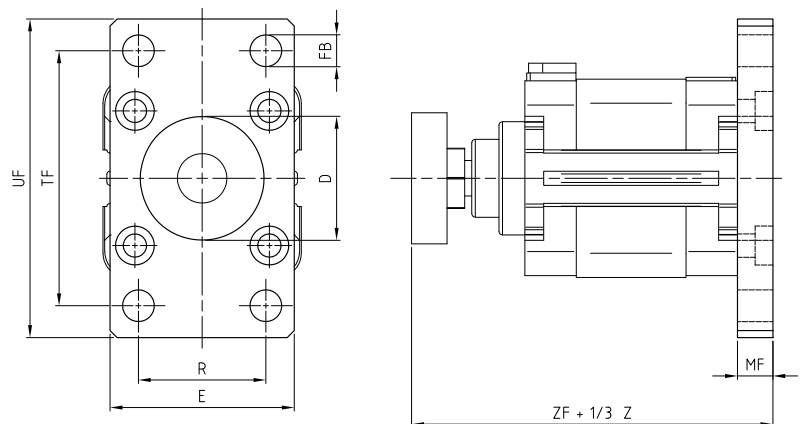

Material: Zinc-plated steel

Z = Stroke

Ø	ØD	E	ØFB	MF	R	TF	UF	W	ZF	ZH	Mass	Part No.
	h11		h13		Js14	Js14						
40	35	52	9	10	36	72	90	2	92	70	250	KF-12040
50	44	65	9	12	45	90	110	3	100	73	500	KF-12050
63	52	75	9	12	50	100	120	3	104	77	650	KF-12063

Female fork with clips

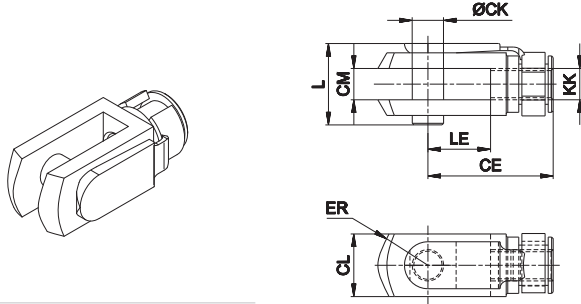

Articulated self-lubricating fork

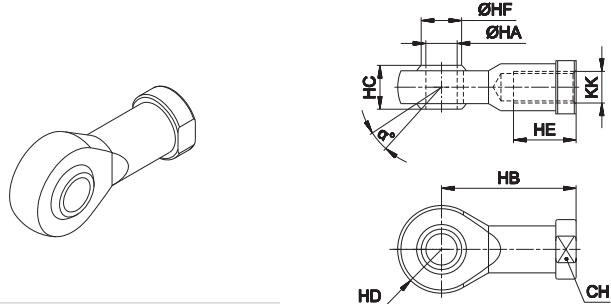

Material: Zinc-plated steel

Material: Zinc-plated steel

Cylinder Ø	CE	CK	CL	CM	ER	KK	L	LE	Mass g	Part no.
40	40	10	20	10	16	M10x1,25	26	20	90	KF-15032
50 - 63	48	12	24	12	19	M12x1,25	32	24	150	KF-15040

Cylinder Ø	α°	CH	KK	HA	HB	HC	HD	HE	HF	Mass g	Part no.
40	13	17	M10x1,25	10	43	14	14 <sup>0-0,12</sup>	20	12,9	76	KF-17032
50 - 63	13	19	M12x1,25	12	50	16	16	22	15,4	110	KF-17040

Fork with pin suitable for piston rod according to ISO 8140 standard

Fork with axially mounted articulated pin

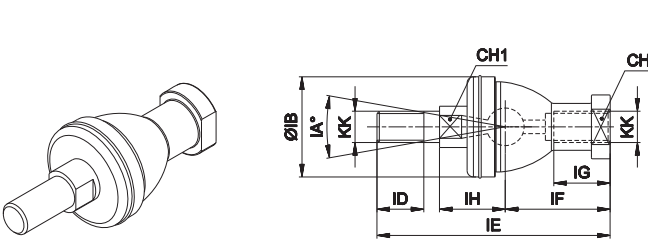

Fork with angle mounted articulated pin

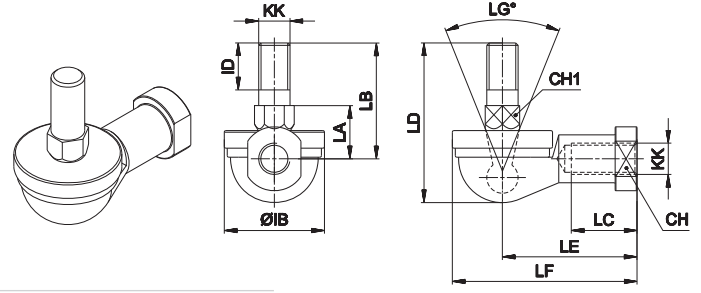

Material: Zinc-plated steel

Material: Zinc-plated steel

Cylinder Ø	CH	CH1	IA°	KK	IH	IB	ID	IE	IF	IG	Mass g	Part no.
40	17	11	30	M10x1,25	19,5 ±0,3	32	15	74,5	35	18	120	KF-22025
50 - 63	19	17	30	M12x1,25	22	36	17	84	40	20	185	KF-22040

Cylinder Ø	CH	CH1	LG°	KK	IB	ID	LA	LB	LC	LD	LE	LF	Mass g	Part no.
40	17	11	50	M10x1,25	32	15	17 ±0,3	37	21	50,5	43	57	110	KF-23025
50 - 63	19	17	50	M12x1,25	36	17	19	42	27	57,5	50	66	165	KF-23040

Floating joint

Piston rod locknut (zinc-plated steel)

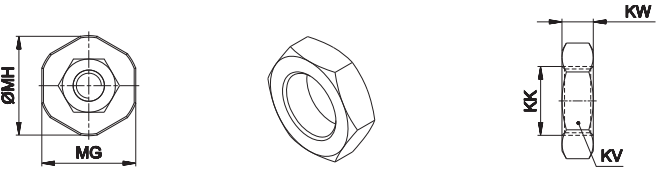
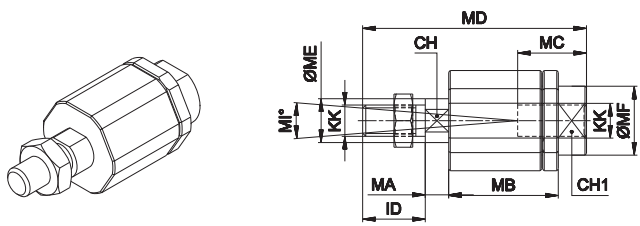

Material: Zinc-plated steel

Material: Zinc-plated steel

Cylinder Ø	CH	CH1	ID	KK	MA	MB	MC	MD	ME	MF	MG	MH	MI°	Mass g	Part no.
40	12	19	71	M10x1,25	5	35	20	71	14	22	30	32	8	220	KF-24032
50 - 63	12	19	75	M12x1,25	5	35	20	75	14	22	30	32	8	230	KF-24040

Cylinder Ø	KK	KV	KW	Mass g	Part no.
40	M10x1,25	17	6	5	KF-16032
50 - 63	M12x1,25	19	7	10	KF-16040