

□19 mm, offset 45 mm

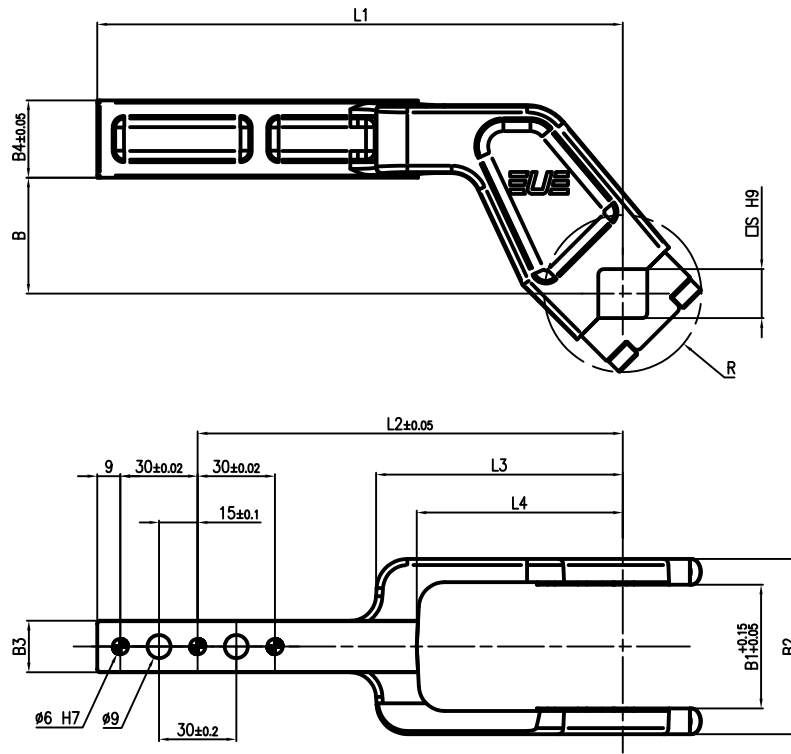

LKP-Code	B	B1	B2	B3	B4	L1	L2	L3	L4	R	S	Material
LKP010-2321	45	48	68	20	30	144	105	95	80	31	19	Steel
LKP010-2322	45	48	68	20	30	204	165	95	80	31	19	Steel

Subject to technical modifications without notice

□19 mm, offset 45 mm

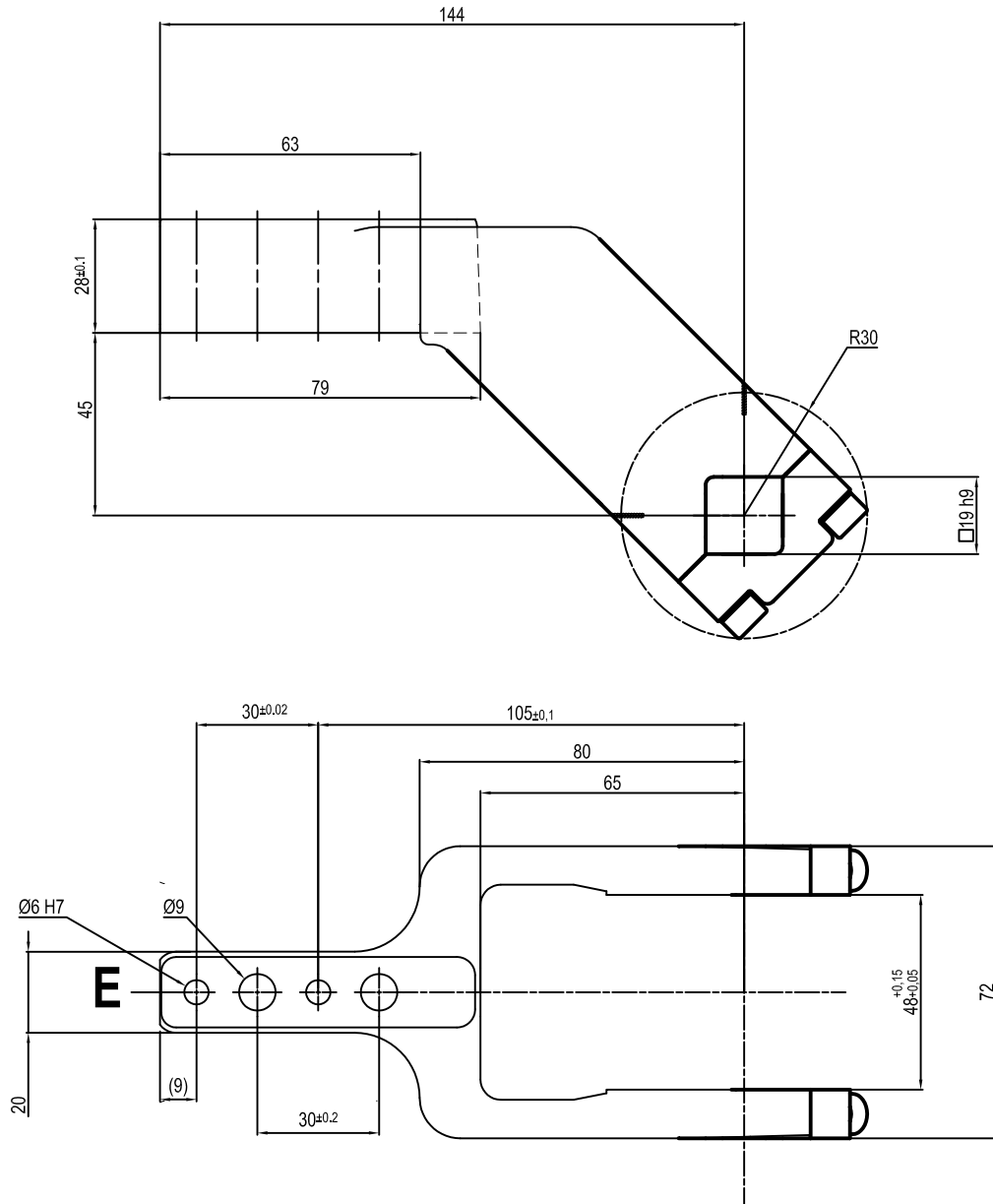

Clamp size	Material	Weight
50/63 mm	Aluminium	0.45 Kg

THE CLAMPING ARM INCLUDES THE NECESSARY SCREWS

Subject to technical modification without notice.

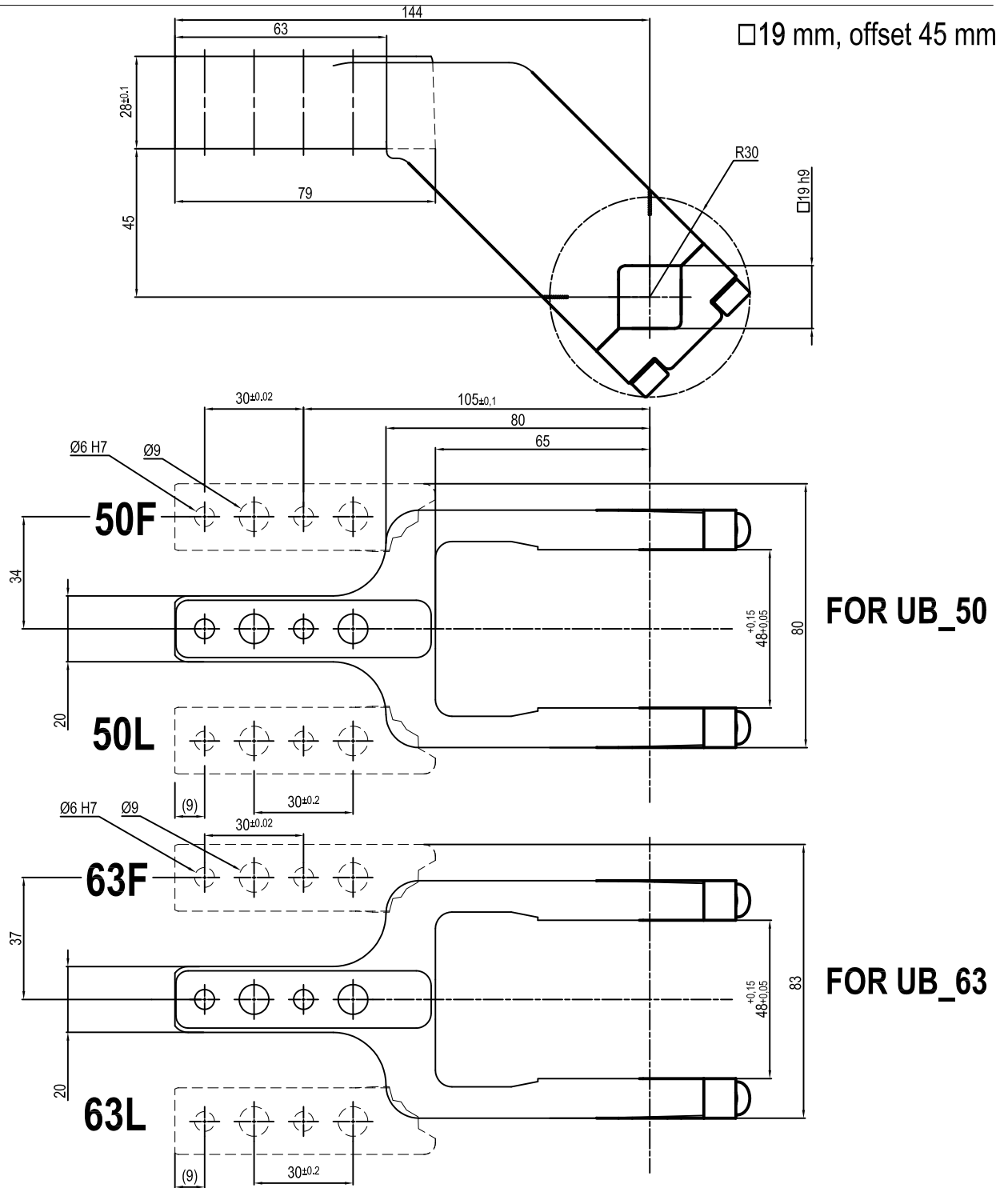

Clamp size	Material	Weight
50/63 mm	Aluminium	0.45 Kg

THE CLAMPING ARM INCLUDES THE NECESSARY SCREWS

Subject to technical modification without notice.

□22 mm, offset 45 mm

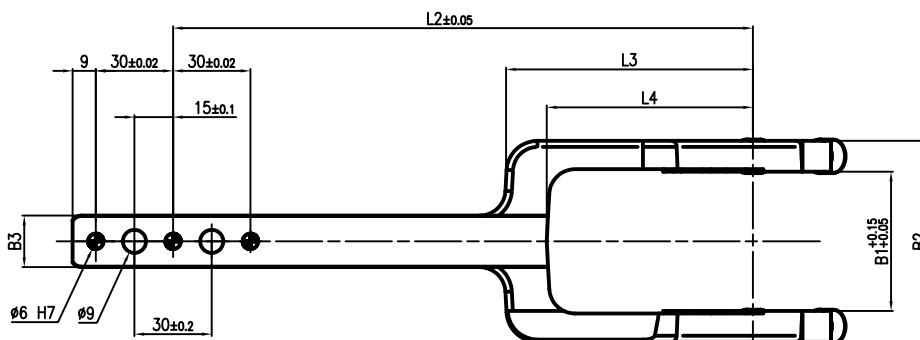
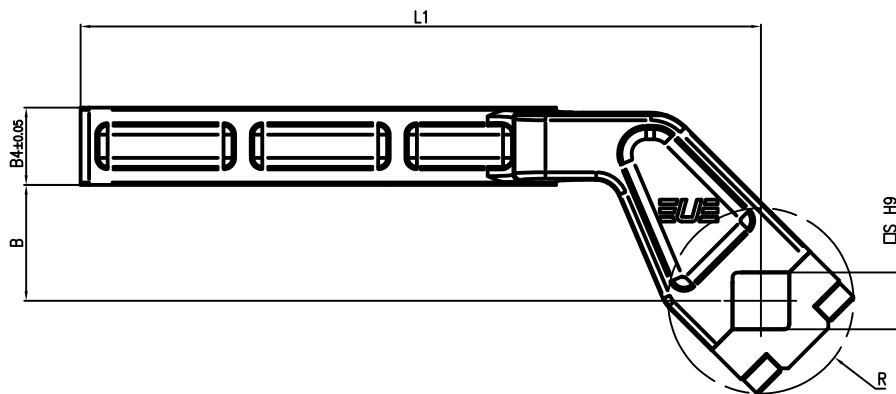

LKP-Code	B	B1	B2	B3	B4	L1	L2	L3	L4	R	S	Material
LKP010-2301	45	54	78	20	30	144	105	95	80	36	22	Steel
LKP010-2302	45	54	78	20	30	204	165	95	80	36	22	Steel
LKP010-2303	45	54	78	20	30	264	225	95	80	36	22	Steel

Subject to technical modifications without notice