

Stock Code	Stock Name	Plate Length	Timing-Belt	Linear Rail Brand	Linear Rail	Maximum Speed
5.03.05.090180.01.0500	90x180 Linear Timing Belt Module	205 mm	8M 50	DMS	GHR 20	5 mt/sn
5.03.05.090180.01.1000	90x180 Linear Timing Belt Module	205 mm	8M 50	THK	HSV 20	5 mt/sn

Body ; 90x180 Profile (Aluminium 6063) T5
Movement Distance Per Tour ; 192mm
Timing Pulley ; 8M-F50 Z=40
Belt Tensile Force ; 3000 N
Timing Belt Pitch ; 8 mm
Positioning Accuracy ; 0,1 mm

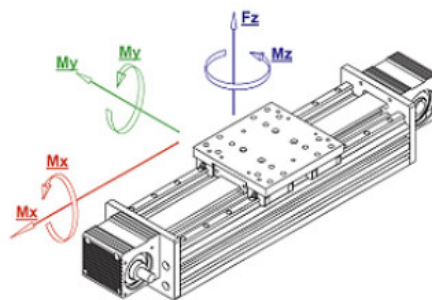
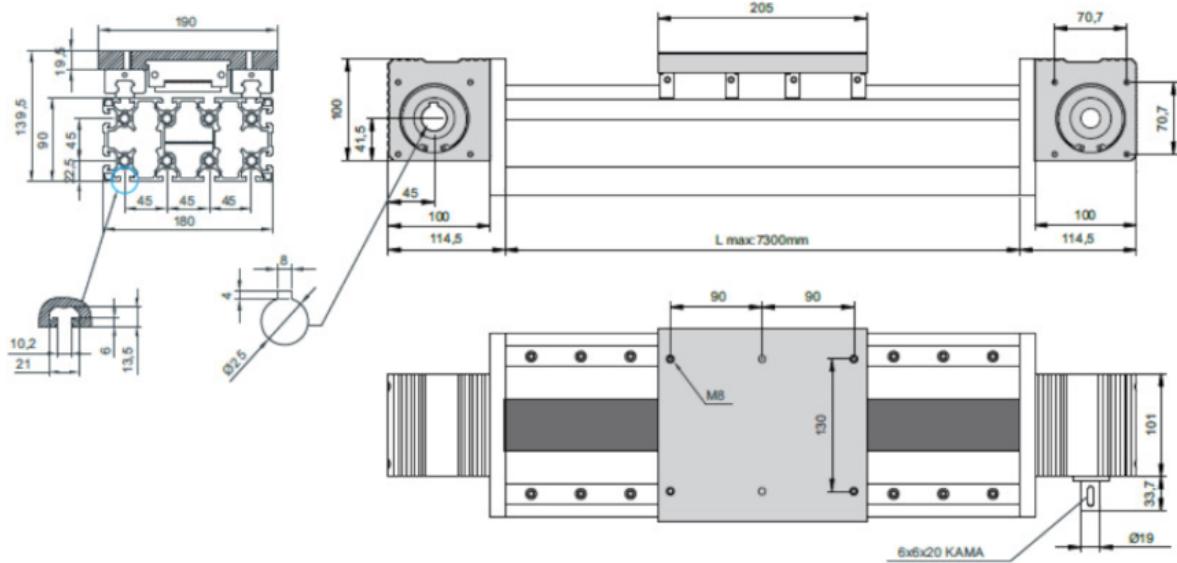

■ F_x	4170	3060
■ F_y	54000	31000
■ F_z	61200	37600
Moment		
■ M_x	2412	1447
■ M_y	3246	1947
■ M_z	3246	1947