

| Stock Code | Stock Name | Plate Length | Timing-Belt | Linear Rail Brand | Linear Rail | Maximum Speed |
|---------------------------|--|--------------|-------------|-------------------|-------------|---------------|
| 5.3.03.080080.2.05.2.0700 | 80x80 Plate Driven Linear Timing Belt Compact Module | 215 mm | 5M 30 | DMS | HGR 20 | 5 m/s |
| 5.3.03.080080.2.05.2.0701 | 80x80 Plate Driven Linear Timing Belt Compact Module | 265 mm | 5M 30 | DMS | HGR 20 | 5 m/s |
| 5.3.03.080080.2.05.2.0705 | 80x80 Plate Driven Linear Timing Belt Compact Module | 215 mm | 5M 30 | THK | HSV 20 | 5 m/s |
| 5.3.03.080080.2.05.2.0706 | 80x80 Plate Driven Linear Timing Belt Compact Module | 265 mm | 5M 30 | THK | HSV 20 | 5 m/s |

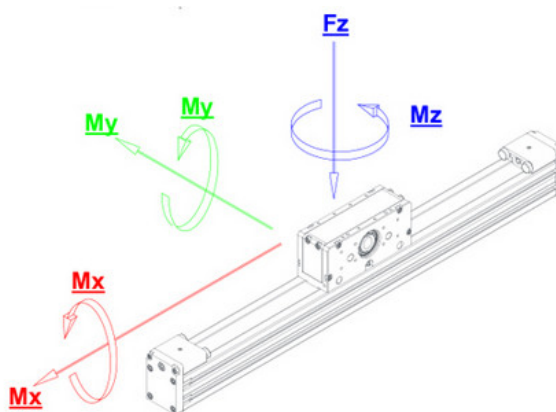
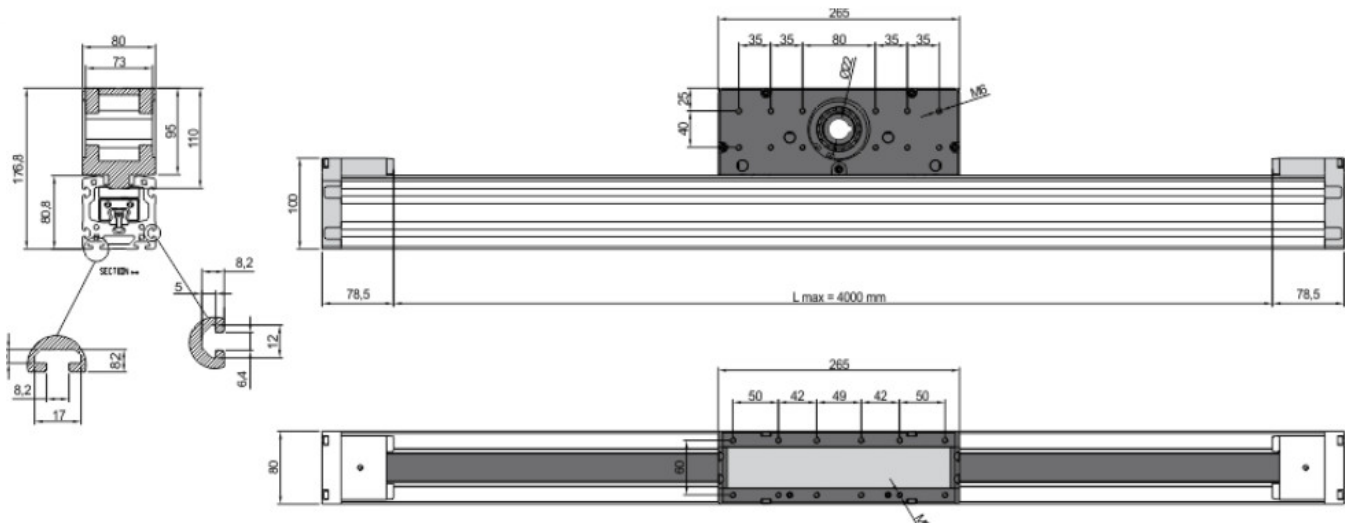

| Load | | Dynamic |
|--|------|---------|
| ■ F_x | (N) | 2400 |
| ■ F_y | (N) | 2760 |
| ■ F_z | (N) | 7220 |
| Moment | | |
| ■ M_x | (Nm) | 415 |
| ■ M_y | (Nm) | 480 |
| ■ M_z | (Nm) | 570 |