

MV 40

REGOLATORE DI FLUSSO

1	2	3	4	5	6	7
Corpo Body Corps Körper	Spillo Needle Epingle Nadel	Pomolo Handwheel Volant moleté Rändelkopf	Bussola Cartridge Cartouche Patrone	Guarnizioni Seals Joint d'étanchéité Dichtung	Anello Banjo Ring Banjo Steckverschraubungen	Rondelle Gasket Bague Plastique Kunststoffring
Ottone UNI EN 12164 CW614N Nichelato Brass UNI EN 12164 CW614N Nickel plated Laiton UNI EN 12164 CW614N Nickelé Messing UNI EN 12164 CW614N vernickelt				NBR NBR NBR NBR	Raccordo serie RA RA line standard fittings Raccords série RA RA Steckverschraubungen	PA6 PA6 PA6 PA6

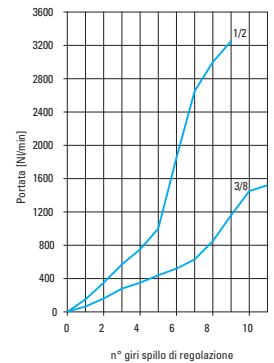
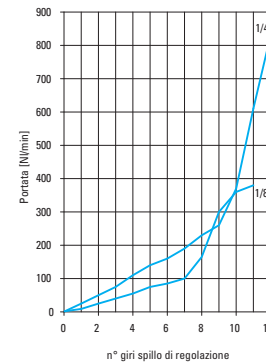
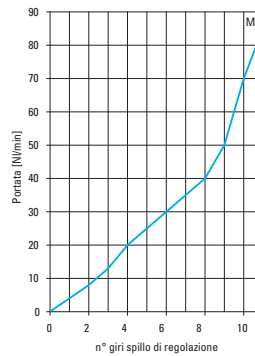
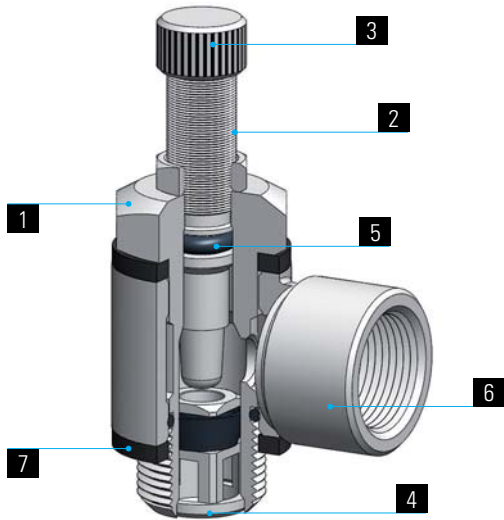

Una volta effettuata l'installazione del regolatore l'anello non è più orientabile.
The banjo ring no longer swivels after flow control installation.
Les banjos ne tournent pas après l'installation du réducteur.
Der Schwenkring bleibt nach der Montage des Drosselrückschlagventiles fest.

SPECIFICHE TECNICHE

Temperatura di esercizio:
-20°C ÷ 70°C
Pressione di esercizio:
0 ÷ 10 bar
Campi di applicazione:
impianti pneumatici alimentati con aria filtrata e lubrificata.

DATA SHEET

Working temperature:
-20°C ÷ 70°C
Working pressure:
0 ÷ 10 bar
Application field:
pneumatic installations fed with filtered, lubricated air.

REINSEIGNEMENTS TECHNIQUES

Température de service:
-20°C ÷ 70°C
Pression de service:
0 ÷ 10 bar
Domaines d'application:
circuits pneumatiques avec air filtré et lubrifié.

TECHNISCHE AUSKÜNFTE

Temperaturbereich:
-20°C ÷ 70°C
Druckbereich:
0 ÷ 10 bar
Anwendungsbereiche:
pneumatische Anlage mit gefilterter und geölter Druckluft.

MV 40

Regolatore con attacco filettato e pomolo di regolazione

Male Flow Control with Handwheel

Réducteur de débit fileté avec volant moleté

Drosselrückschlagventil mit Gewinde und Rändelkopf

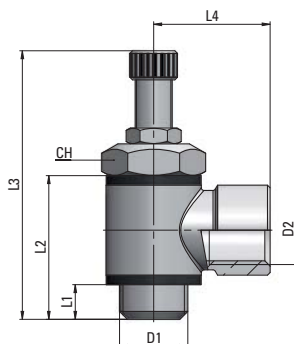

Tipo	D1	D2	L1	L2	L3 max	L4	CH	g
40 00 M5	M5x0,8	M5x0,8	4	16	38,5	11	8	12
40 00 18	G1/8	G1/8	5	24	42,5	16	14	37
40 00 14	G1/4	G1/4	6,5	27,5	51	22	17	65
40 00 38	G3/8	G3/8	7	31	63	26	20	112
40 00 12*	G1/2	G1/2	9	38	81	32	26	202

* Solo-Only-Seulement-nur .../C - .../B

Disponibile nelle versioni:

.../C



.../V



.../B

